



CEREALS PROCESSING CHAIN



CLIMA4
Linking you to EXCELLENCE since 1926

JOHN KING



JOHN KING & COMPANY

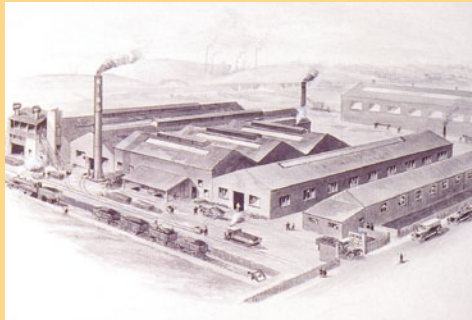

Climax Works 1930's



Chain Assembly 1960's



New Climax Works 2000's

Company History and Qualifications

The John King Company was established in Leeds, England in 1926. Early success was achieved in the manufacture of mechanical handling equipment for the rapid mechanisation of the coal industry. In these early days conveyor chain was generally of cast link construction. The Company therefore has unrivalled experience in the production of highest quality cast link chains in ductile irons and steel under the "Climax Quality Brand". JOHN KING are undoubtedly the world leaders in this range of conveying chains.

Although cast link chains remain an important part of the JOHN KING programme, the company has progressively expanded the product range to encompass chains of other constructions and manufacturing techniques including Welded steel chains, engineered steel chains, forged fork link chains and Engineering plastic chains. Today JOHN KING offer the widest range of conveyor chains of any manufacturer which makes them unique in being able to offer an infinite number of chain types in a variety of materials and constructions for a multiplicity of industry mechanical handling applications.

In recent years it has been JOHN KING's strategy to develop the Company into a global business. This has seen the establishment, in addition to the United Kingdom, of a chain production plant in the US. John King USA Inc from their plant in East Peoria (IL) are well equipped with the manufacturing equipment for component production and assembly processes for high quality chain production serving North America. To provide best service in export markets the companies has warehousing and distribution worldwide and maintain ambition plans to expand the network further in the future.

All products are manufactured within the dictates of the Company's quality management according to ISO 9000 establishing consistent and high quality products and ensuring performance reliability and extended service life.

CONTENTS

Cast Combination Trough Scraper Chains **03** | Combination Elevator Chains **04** | Flush Roller Box Scraper Chain **05** | Twin Trace Roller Chains **06** | 81X Chains 'The Grain Chain' **07** | Metric Trough Scraper Chains as M Series DIN 8167 **08** | Metric Trough Scraper Chains as FV Series DIN 8165 **09** | Forged Link Standard Series **10** | Typical Flight Arrangements **11** | Plastic Sleeves for Standard Forged Chains **12** | High Manganese Wear Rail **12** | Engineering Plastic Flight – TUFFLE X® with Unique Mounting Arrangement (Patent Pending) **12** | Offset Sidebar Welded Steel Chains **13** | Offset Sidebar Heavy Duty Bush Chains **14**

Photos courtesy of Perry Engineering Devon England
www.Perryengineering.com



Cast Combination Trough Scraper Chains

John King have been the principal producer of cast combination chain for many years. This includes the flighted version typically employed in grain conveyors with a cast integral flight. Their experience is essential in material selection which combines strength and wear resistance as well as ductility. An additional version is available on C664 and C762 where an injection moulded plastic flight is riveted to the outer link. For corrosion resistance chains can be produced with stainless steel pins, a typical example being green malt conveying.

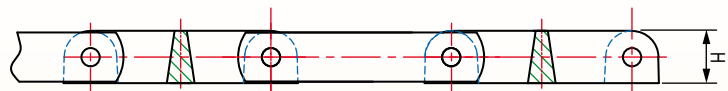
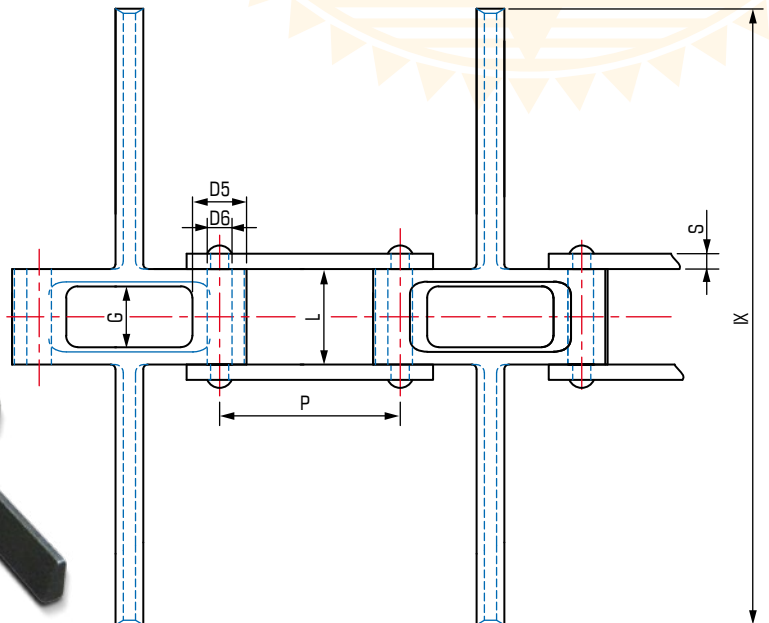

Cast Combination Trough Scraper Chains

Chain Number	P	Working Load	Average Weight	Barrell	Between Sidebars	Gearing	Sidebars		Pin Diameter	Overall Width
				Outside Diameter			Thickness	Height		
				D5			S	H		
							mm			
C586/T2X5	58.6	6,000	2.89	17	32	20	5	16	8	124
C586/T2X8	58.6	6,000	3.37	17	32	20	5	16	8	200
C586/T4X8	58.6	6,000	2.87	17	32	20	5	16	8	200
C664/T2X8	66.4	12,000	5.24	23	37	25	5	20	11	200
C664/P2X8 *	66.4	12,000	3.89	23	37	20	5	16	8	200
C664/T2X9	66.4	12,000	5.90	23	37	25	5	20	11	220
C762/T2X12	76.2	24,000	10.86	32	43	26	6	30	14	290
C762/P2X12 *	76.2	24,000	7.86	32	43	26	6	30	14	290
C762/T2X15	76.2	24,000	11.80	32	55	35	6	30	14	370

NR – Noise Reduction feature with deep link plate.

* P – Moulded engineering plastic flight riveted to outer link in place of cast flight. Available on C664 and C762.



Combination Elevator Chains

For grain elevators where the product is transported from the horizontal up a "swan neck" this is commonly seen to employ the cast combination chain with an F attachment. To the attachment a wiper blade is fixed which acts as the conveying medium. Three standards are typical as OEM replacements but a variety of widths can be produced if so required.

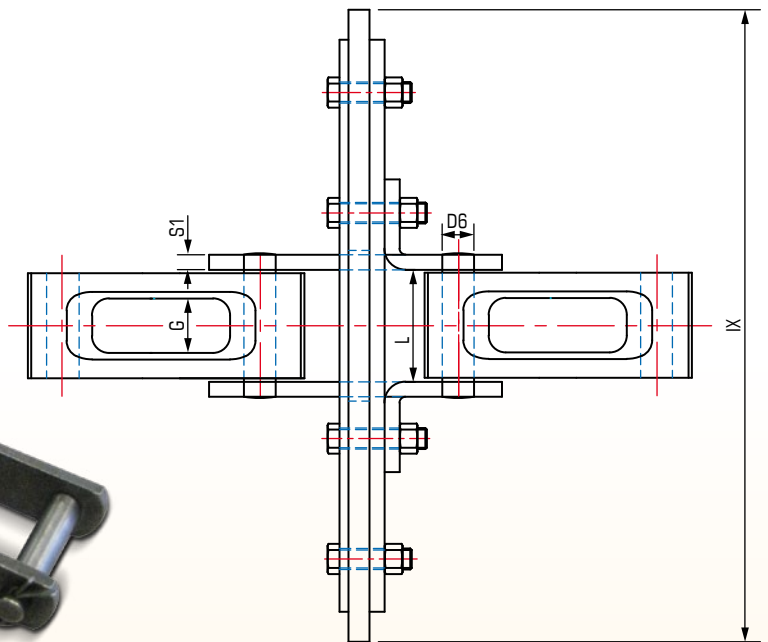
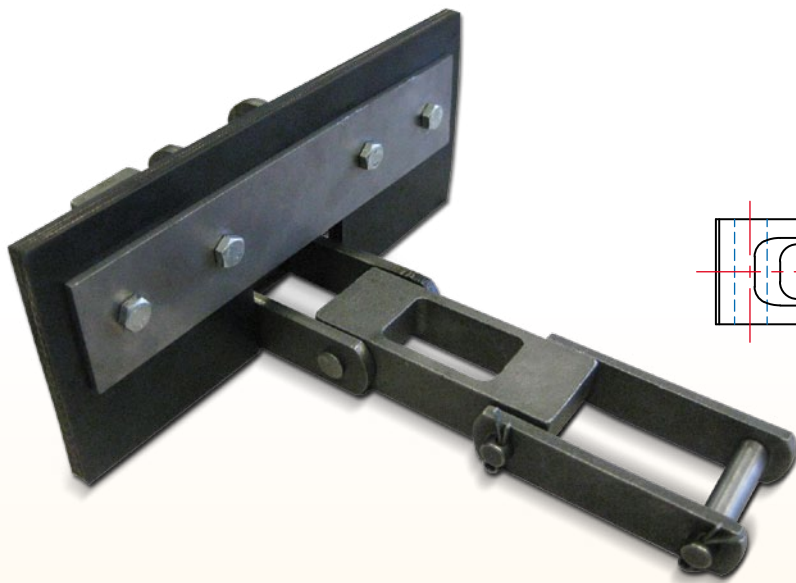
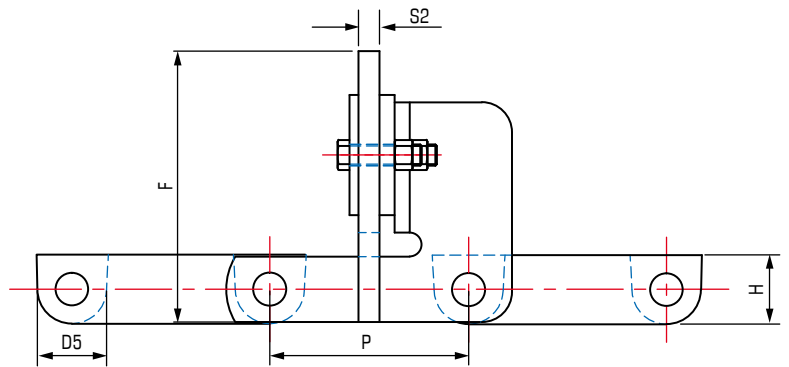

Combination Elevator Chains

Chain Number	p	Breaking Load	Average Weight	Bushings	Between Sidebars	Gearing	Sidebars			Pin Diameter	Overall Width	Overall Flight Height
				Outside Diameter			Thickness		Height			
				D5			S1	S2	H			
C664/F4X190	66.4	12,000	6.98	23	37	25	5	8	20	11	190	90
C664/F4X210	66.4	12,000	7.12	23	37	25	5	8	20	11	210	90
C762/F4X280	76.2	24,000	12.8	32	43	30	6	10	30	14	280	115



Flush Roller Box Scraper Chains

This series conforms to the British standard BS 4116 in all areas apart from D2 roller diameter. In this case the chain employs a flush style roller which is equivalent in diameter to the link plates height. This flush roller is not therefore a carrier style but will allow for improved sprocket gearing inter action as compared to a bush style chain. Flights are normally BT style being bent integral, but WT the welded version are also an option. OEM standards follow fixed IX dimensions being the overall flight width however other options are of course available on request.

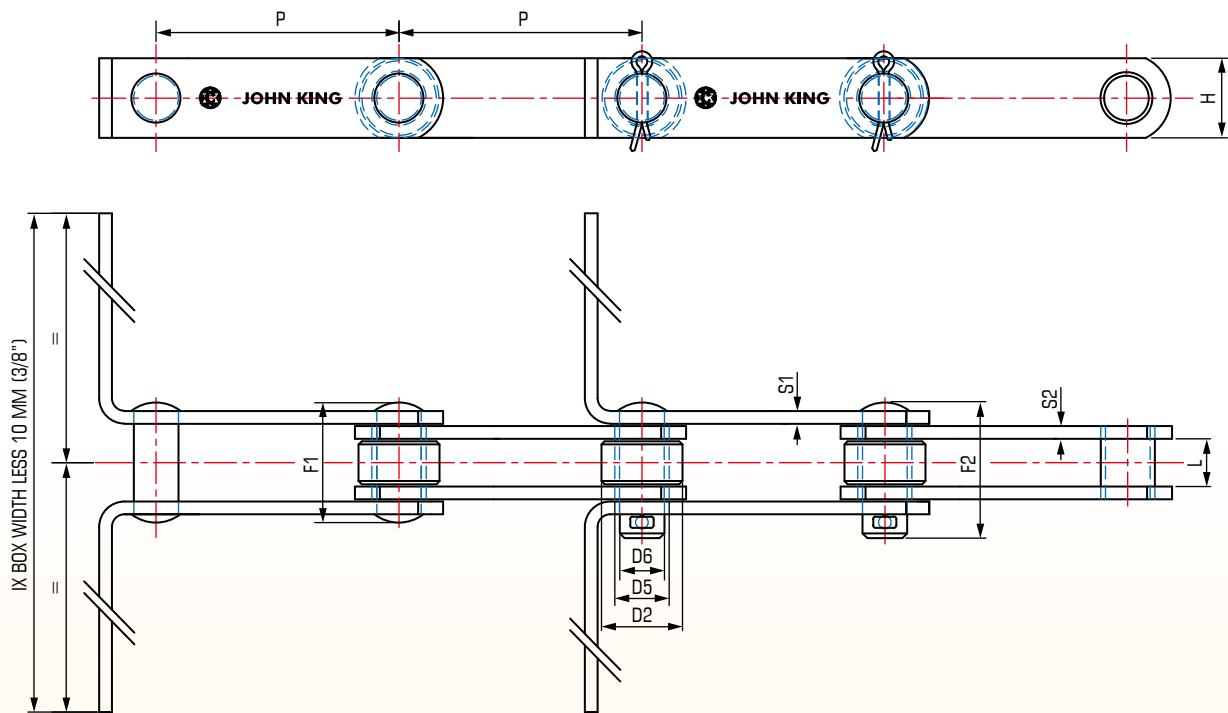

Flush Roller Box Scraper Chains

Chain Number	P	Breaking Load		Average Weight**	Rollers	Bushings Outside Diameter	Between Sidebars	Sidebars			Pins	Overall Width			
								Thickness		Height		Diameter	F1	F2	IX
								S1	S2						
SP43/0762/R1/BT	76.2	43	70	TBA	25.4	17	15	4	4	25	14	37	42	TBA***	
SP43/1016/R1/BT	101.6	43	70	TBA	25.4	17	15	4	4	25	14	37	42	TBA***	
SP75/1016/R1.5/BT	101.6	75	125	TBA	38.1	23.6	19	5	4	40	19	43	50	TBA***	
SP75/1524/R1.5/BT	152.4	75	125	TBA	38.1	23.6	19	5	4	40	19	43	50	TBA***	

* Heat treated sidebars – double strength.

** Variance based on flight width. To be advised. Dimensions as required by customer.

*** Flight width IX to suit customer requirements.



Twin Trace Roller Chains

This format is a popular choice in milling applications. Chains conform to British standard BS 4116 and operate in twin strand format with strands made common with a flight bar bolted to a welded angle iron L style attachment.

Often described as shrouded chain is encapsulated within a channel form as part of the conveyor panel profile and as such is separated from the material. Clearly the UTS is double that of single strand, the real advantage is an open discharge area which is beneficial for sticky materials and reduced carry over.

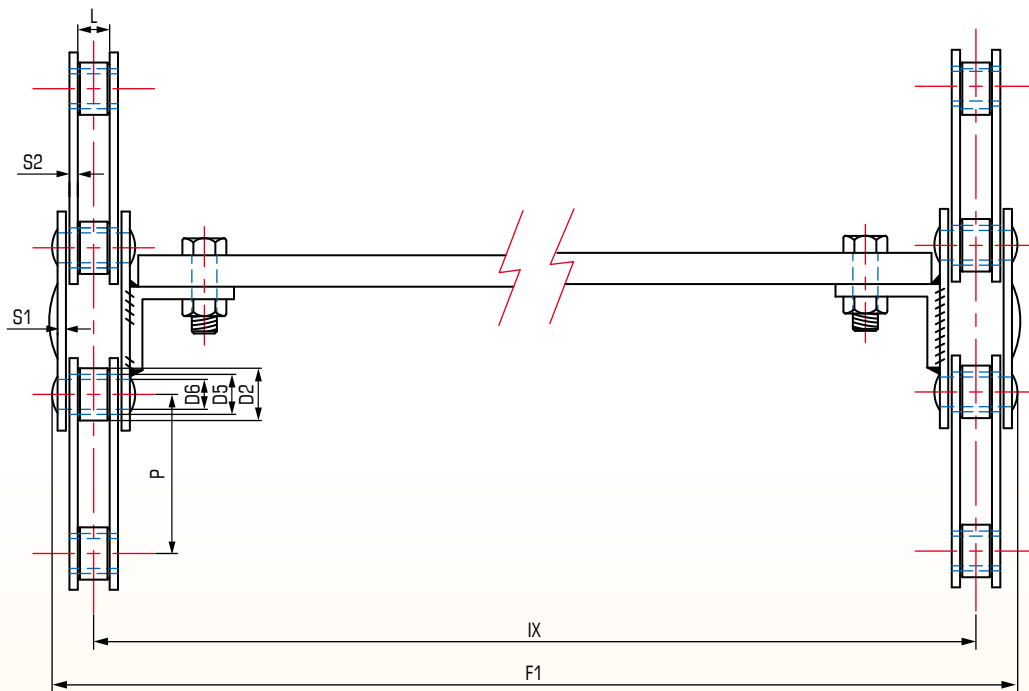

Twin Trace Roller Chains

Chain Number	P	Breaking Load Per Strand		Average Weight	Rollers	Bushings		Between Sidebars	Sidebars			Pins	Overall Width	
						Outside Diameter	L		Thickness		Height			
						D2	D5		S1	S2	H	D6	IX	F1
SP43/0762/12/14	76.2	43	70	TBA*	31.75	17	15	4	4	25	14	TBA**	IX + 37	
SP43/1016/12/14	101.6	43	70	TBA*	31.75	17	15	4	4	25	14	TBA**	IX + 37	
SP75/0762/12/14	76.2	75	125	TBA*	47.6	23.6	19	5	4	40	19	TBA**	IX + 43	
SP75/1016/12/14	101.6	75	125	TBA*	47.6	23.6	19	5	4	40	19	TBA**	IX + 43	
SP135/1016/12/14	101.6	135	200	TBA*	66.7	33	25.4	7	5	50	26.9	TBA**	IX + 56	
SP135/1524/12/14	152.4	135	200	TBA*	66.7	33	25.4	7	5	50	26.9	TBA**	IX + 56	

* Weight per metre based on dimension IX therefore to be advised.

12 Flight every outer link.

14 Flight every second outer link.

** Flight width IX to suit customer requirements.



81X Chains 'The Grain Chain'

Worldwide the most common running gear encountered is the American roller chain series 81X. This we therefore describe as the GRAIN CHAIN. It is always 2,609" pitch (66,27 mm). As duties have increased a demand for a heavy duty version and extra heavy duty version has developed. This has been achieved by increasing the height and thickness of the side plates, although maintaining the same gearing details. Where necessary therefore the heavier versions can be used to upgrade existing equipment. Flights are normally WT the welded version but John King uniquely offer BT style being bent integral produced to customer standards.

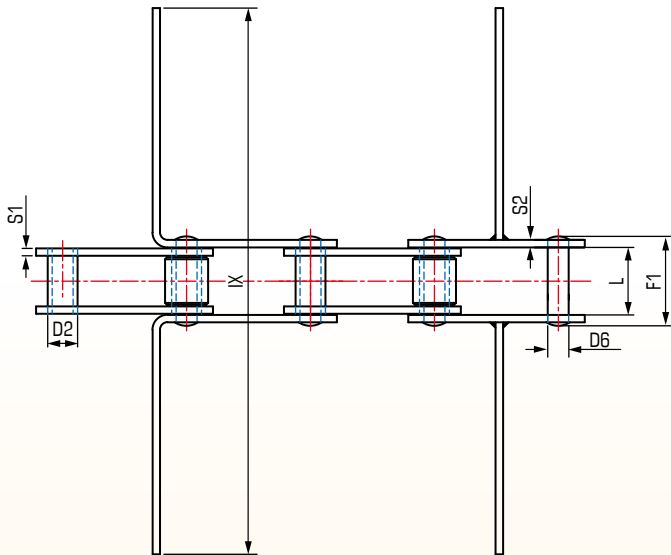
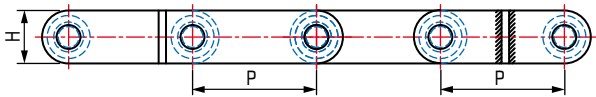

81X Chains 'The Grain Chain'

Chain Number	P mm	Tensile Strength kN	Rollers		Plate			Pin		Overall Width
			Diameter	Width	Thickness		Height	Diameter	Length	IX
			D2	L	S1	S2	H	D6	F1	
JKR 81X	66.27	111	23	27	4	4	28.58	11.11	47.2	TBA*
JKR 81XH	66.27	176	23	27	7.94	5.56	31.75	11.11	58.2	TBA*
JKR 81XHH	66.27	186	23	27	7.94	7.94	31.75	11.11	63.5	TBA*

* Flight width IX to suit customer requirements.
Flight Options:
- WT denoted flight welded to side plate mid pitch,
- BT denotes flight bent integral with linkplate.



Metric Trough Scraper Chains as M Series DIN 8167

Throughout Europe metric standard chain is used in trough conveyors for grain transport. M series according to DIN 8167 is the most typical of the two main ranges that are predominant. The chains are exactly as the standard but in bush form without roller. The flights are normally BT style being bent integral and these are normally produced to customer preference, but WT the welded version allows for quick supply from stock plain chain.

As these chains are produced in larger volumes they generally prove to be an economic option.

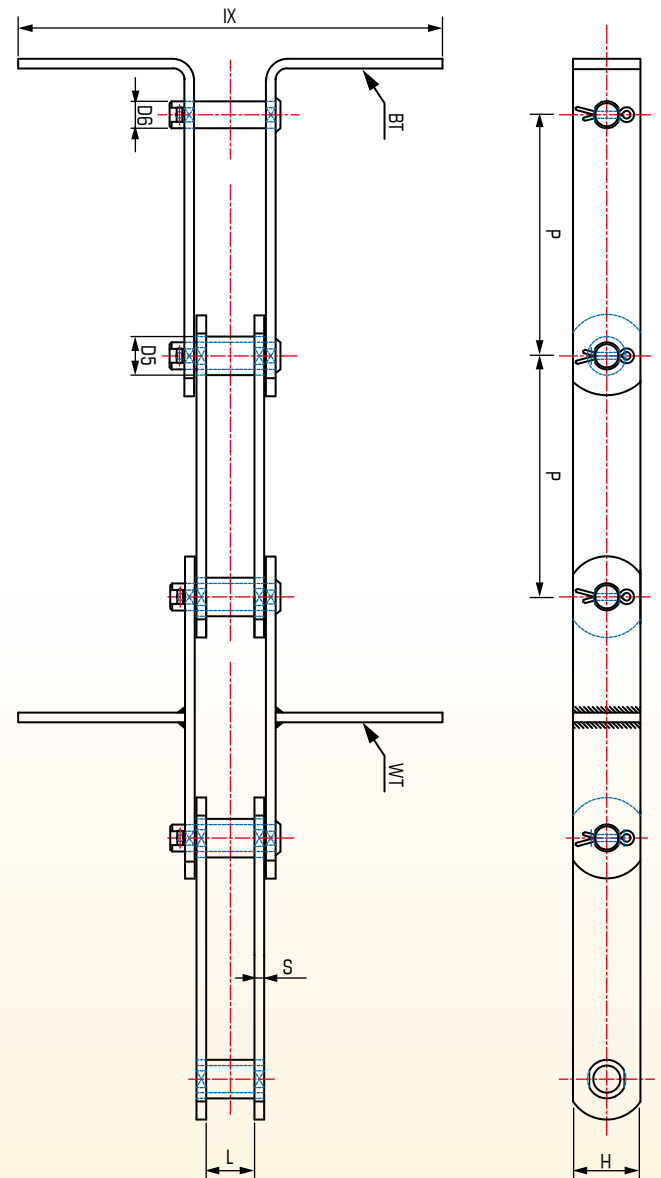

Metric Chains (M Series) DIN 8167

Chain Number	P	Breaking Load kN	D5	L	S	H	D6	IX
	mm							
MR 56/063	63	56	10	24	4	30	15	
MR 56/080	80							
MR 56/100	100							
MR 56/125	125							
MR 56/160	160							
MR 80/080	80	80	12	28	5	35	18	
MR 80/100	100							
MR 80/125	125							
MR 80/160	160							
MR 80/200	200							
MR 112/080	80	112	15	32	6	40	21	
MR 112/100	100							
MR 112/125	125							
MR 112/160	160							
MR 112/200	200							
MR 160/100	100	160	18	36	7	50	25	
MR 160/125	125							
MR 160/160	160							
MR 160/200	200							
MR 160/250	250							
MR 224/125	125	224	21	42	8	60	30	
MR 224/160	160							
MR 224/200	200							
MR 224/250	250							
MR 315/160	160							
MR 315/200	200							
MR 315/250	250							
MR 315/315	315							

dimension as required

Chains can be supplied riveted or cottered on both sides.

Flight Options:

- WT denoted flight welded to side plate mid pitch,
- BT denotes flight bent integral with linkplate.

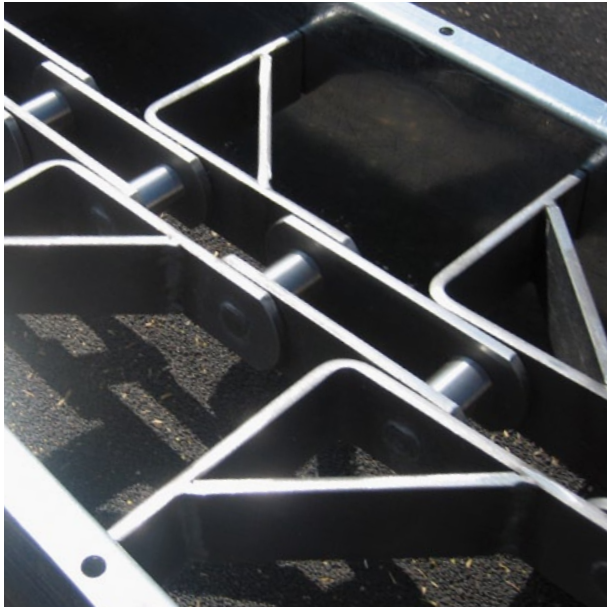

Metric Trough Scraper Chains as FV Series DIN 8165

As with M series, FV chains are predominant. FV chains conform to DIN 8165 and as with M series are a good commercial option. The reference can be easily followed with prefix denoting the breaking strength in kilo newtons and the suffix being the pitch. The flights are normally BT style being bent integral and these are normally produced at widths to suit customer preference, but WT the welded version allows for quick supply from stock plain chain.

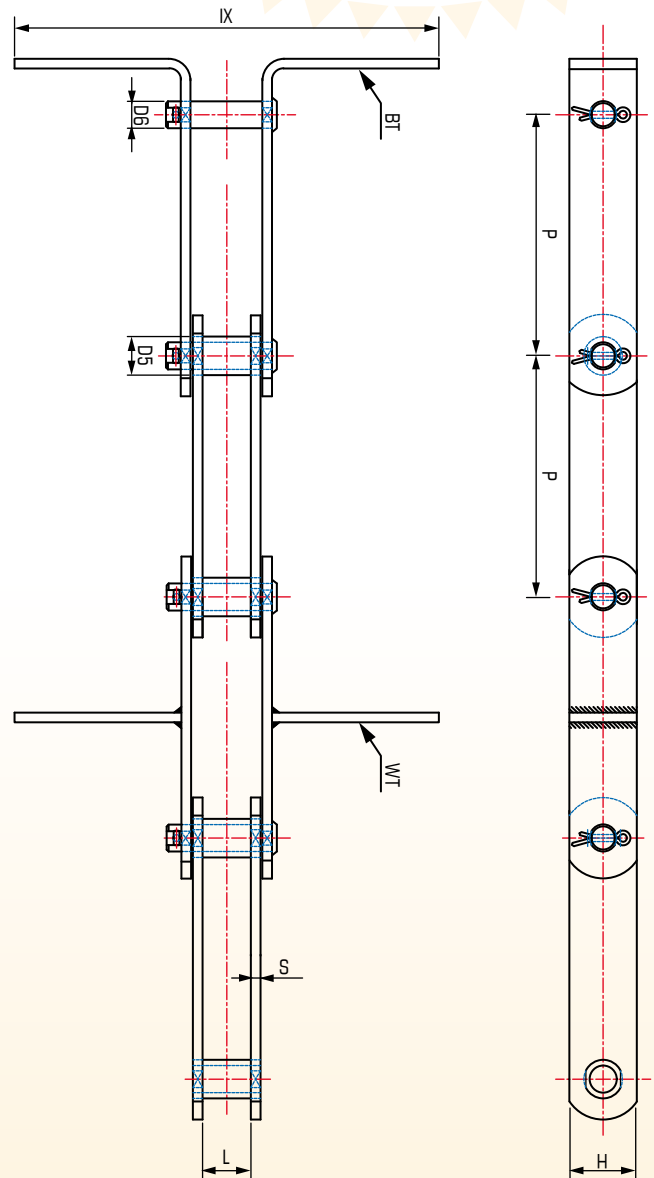

Metric Chains (FV Series) DIN 8165

Chain Number	P	Breaking Load kN	D5	L	S	H	D6	IX	dimension as required
	mm								
FVR 40/040	40	40	10	18	3	25	15		
FVR 40/063	63								
FVR 40/080	80								
FVR 40/100	100								
FVR 63/063	63	63	12	22	4	30	18		
FVR 63/100	100								
FVR 63/125	125								
FVR 63/160	160								
FVR 90/100	100	90	14	25	5	35	20		
FVR 90/125	125								
FVR 90/160	160								
FVR 90/200	200								
FVR 112/100	100	112	16	30	6	40	22		
FVR 112/125	125								
FVR 112/160	160								
FVR 112/200	200								
FVR 140/100	100	140	18	35	6	45	26		
FVR 140/125	125								
FVR 140/160	160								
FVR 140/200	200								
FVR 180/125	125	180	20	45	8	50	30		
FVR 180/160	160								
FVR 180/200	200								
FVR 180/250	250								
FVR 250/125	125	250	26	55	8	60	36		
FVR 250/160	160								
FVR 250/200	200								
FVR 250/250	250								
FVR 315/160	160	315	30	65	10	70	42		
FVR 315/200	200								
FVR 315/250	250								
FVR 315/315	315								

Chains can be supplied riveted or cottered on both sides.

Flight Options:

- WT denoted flight welded to side plate mid pitch,
- BT denotes flight bent integral with linkplate.



John King Forged Link Standard Series

This series represents the leading product within the John King programme. Forged fork link chain has proven to be one of the most reliable conveying mediums offering a combination of versatility, strength and abrasion resistance. These chains, originally of European origin, are now established worldwide. With a wide variety of materials, heat treatments and flight formats the chain is established in both drag and enmasse handling.

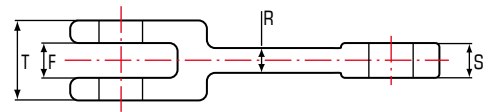
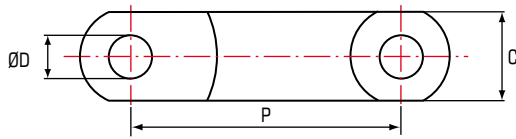

Forged Link Standard Series

Chain Number	P	T	C	S	F	R	Bolt Hole Diameter D	Breaking Loads			Weight kg/m
								TN*	CN*	CD*	
JKF 10160	101.6	24	36	8	10	6	14	110	120	210	3.50
JKF 10160R	101.6	30	36	13	14	9	14	180	195	330	4.80
JKF 12514	125	30	36	13	14	10	16	163	175	290	4.40
JKF 14214	142	30	40	13	14	9	18	180	195	330	4.90
JKF 14218	142	42	50	19	20	11	25	290	320	550	9.40
JKF 14222	142	54	50	25	27	16	25	370	400	655	12.20
JKF 14226	142	62	50	28	30	15	25	440	470	790	13.60
JKF 16018	160	46	46	22	24	15	22	320	342	560	9.30
JKF 16025	160	50	53	23	25	13	25	370	400	655	10.80
JKF 20025	200	60	50	25	27	18	25	380	410	670	11.30
JKF 20028	200	66	60	30	32	20	30	500	540	900	16.70
JKF 21640	216	64	72	26	28	20	35	585	630	1035	20.10
JKF 22040	220	64	72	26	28	20	35	585	630	1035	20.30
JKF 22050	220	58	75	28	30	25	32	710	760	1260	19.10
JKF 22060	220	71	75	31	33	21	35	735	790	1300	22.90
JKF 25040	250	70	75	32	34	18	32	735	860	1430	18.80
JKF 26035	260	65	75	31	33	20	32	840	900	1480	19.80
JKF 26040	260	70	75	31	33	20	32	840	900	1480	21.00
JKF 26045	260	78	75	35	37	20	32	930	1000	1650	21.80

* TN – Manganese Chrome Alloy Steel (20MnCr5) Case hardened
 CN – Chrome Nickel Alloy Steel (18NiCoMo5) Case Hardened
 CD – Chrome Moly Alloy Steel (42CrMo4) Hardened & Tempered

Typical Flight Arrangements

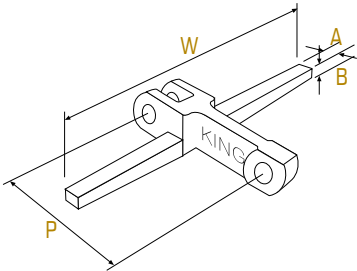

'BT' Bar Flight

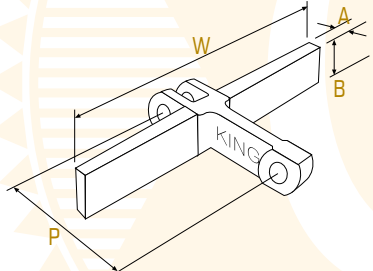

'T' Plate Flight

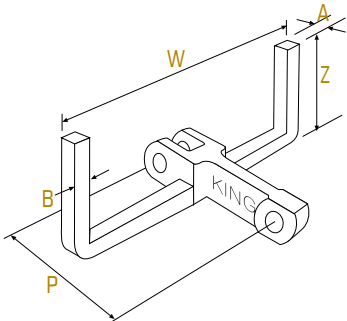

'U' Flight

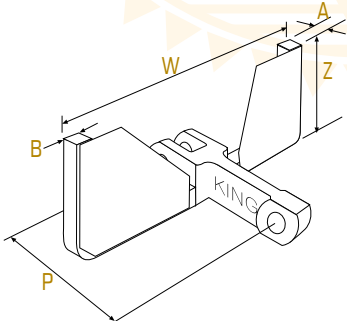

'U' Flight With Blanking

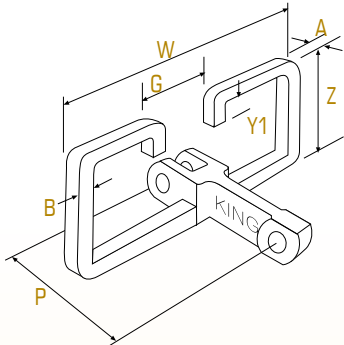

'OO' Flight

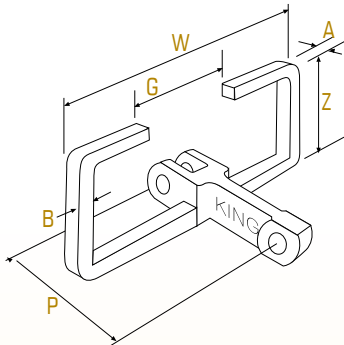

Closed 'C' Flight

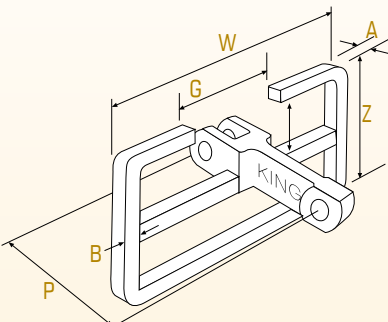

'H' Flight

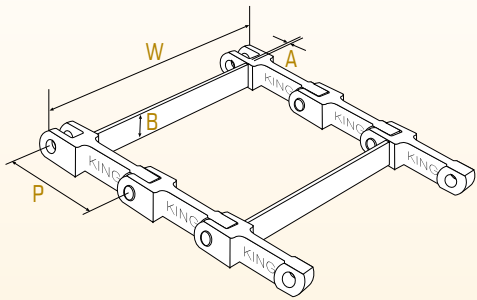

'I' Flight

Cereals Processing Chain

Plastic Sleeves for Standard Forged Chains

Flight Material

- Extruded UHMW Polyethylene.

All measurements in mm.

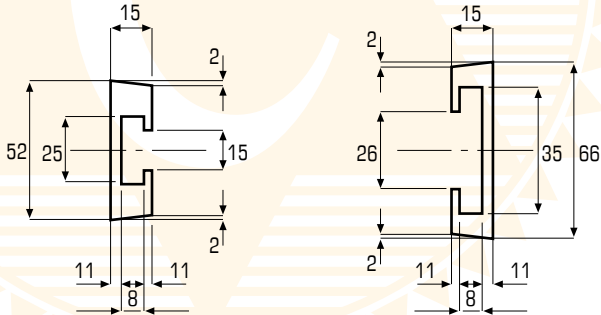

10160
10160R

14218
14226

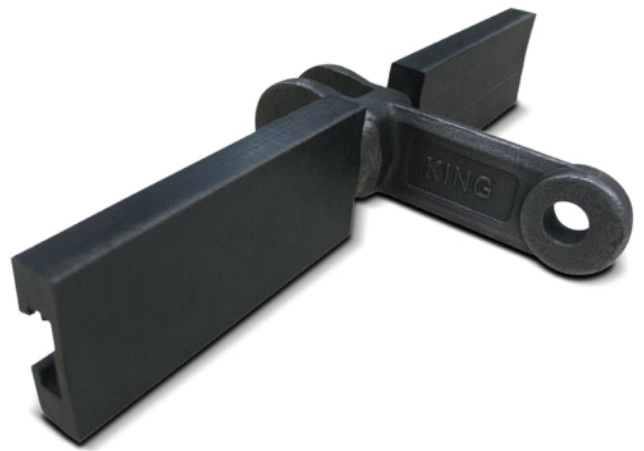
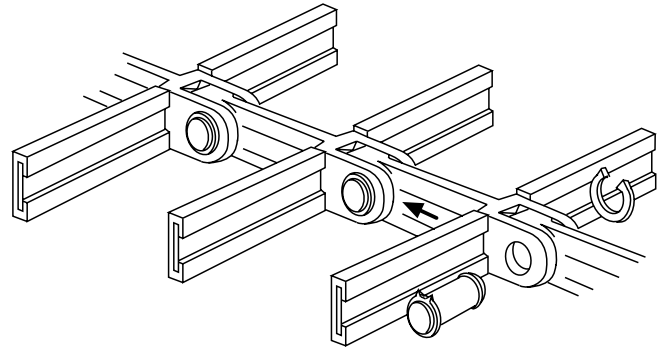

High Manganese Wear Rail

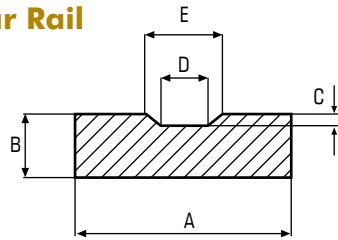

	A	B	C	D	E	Weight
	mm					kg/m
49/4010	40.0	10.0	2.0	5.0	12.0	3.01
49/5010	50.0	10.0	2.0	5.0	12.0	3.82
49/6010	60.0	10.0	3.0	6.0	16.4	4.45
49/6012	60.0	12.0	2.5	12.0	14.0	5.50
49/6020	60.0	20.0	3.0	6.0	16.4	9.15

Engineering Plastic Flight – TUFFLEX® with Unique Mounting Arrangement (Patent Pending)

Flight Material

- High Impact Resistant Engineering Plastic (For options refer to our technicians)

Flight No.	Max Width	
	inches	mm
10160R	15.50	395
14218	29	740
14226	30	760

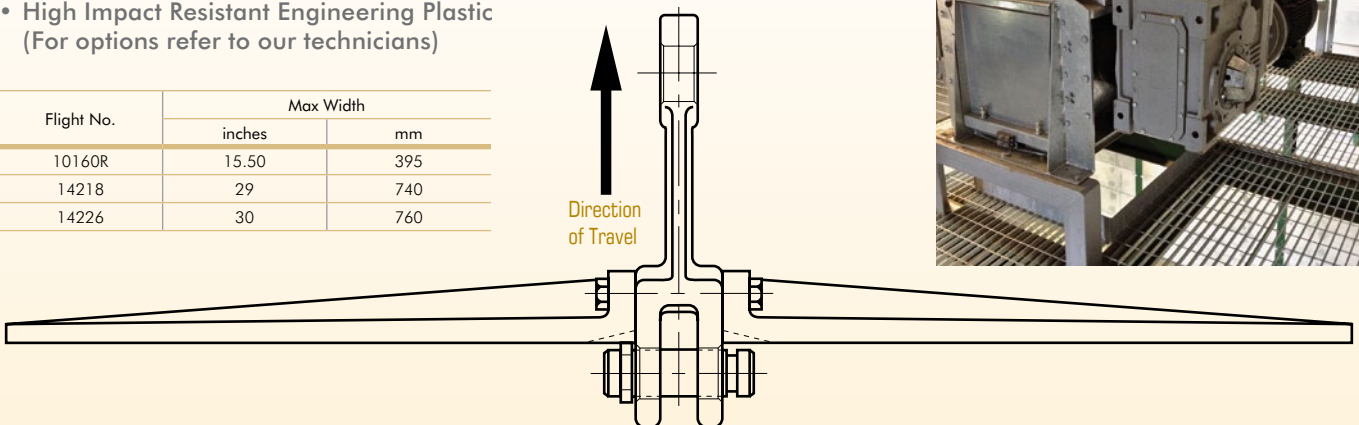



Offset Sidebar Welded Steel Chains

JOHN KING Welded Steel Chains have become a preferred choice in many high duty grain handling applications. The series employs an offset side plate, a bush circumferentially welded to the side plate with a pin subject to heavy interference fit of normally cottered construction. The side bar crank profile includes a "long landing" to allow maximum area for welding. The standard KING chain has heat treated parts, including an induction hardened pin for optimum performance in high duty applications. The chain is generally utilised with polyethylene flights of various forms bolted to steel backing plates which in turn are welded to the chain.

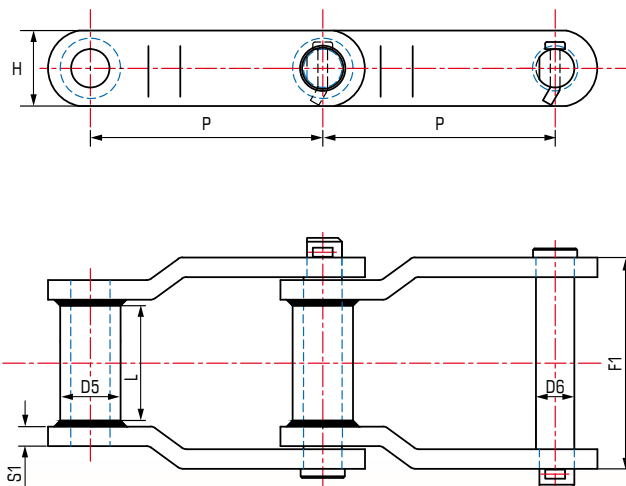

Offset Sidebar Welded Steel Chains

Chain Number	P	Breaking Load	Average Weight	Bushings	Between Sidebars	Sidebars		Pins	Length of Bearing	Overall Pin & Cotter
				Outside Diameter		Thickness	Height	Diameter		
				D5		S	H	D6		
in	lbs	lbs/ft		L	inches					
WHX 78/C	2.609	33,000	4.30	0.84	1.00	0.25	1.25	0.50	2.00	3.00
WHX 82/C	3.075	36,000	4.70	1.00	1.13	0.25	1.25	0.56	2.25	3.38
WHX 124/C	4.000	57,000	7.80	1.25	1.50	0.38	1.50	0.75	2.75	4.25
WHX 111/C	4.760	60,000	8.60	1.25	1.75	0.38	1.75	0.75	3.38	4.81
WHX 110/C	6.000	50,500	7.00	1.25	1.88	0.38	1.50	0.75	3.00	4.00
WHX 106/C	6.000	60,000	6.20	1.25	1.50	0.38	1.50	0.75	2.75	4.25
WHX 132/C	6.050	122,000	14.10	1.75	2.75	0.50	2.00	1.00	4.41	6.38
WHX 150/C	6.050	122,000	16.30	1.75	2.75	0.50	2.50	1.00	4.41	6.50
WHX 155/C	6.050	175,000	19.00	1.75	2.75	0.56	2.50	1.13	4.44	6.41
WHX 157/C	6.050	175,000	20.00	1.75	2.75	0.63	2.50	1.13	4.63	6.75
WHX 159/C	6.125	210,000	26.00	2.00	2.75	0.63	3.00	1.25	4.63	6.75
WHX 200/C	6.125	190,000	22.10	2.00	2.75	0.63	2.50	1.25	4.63	6.75

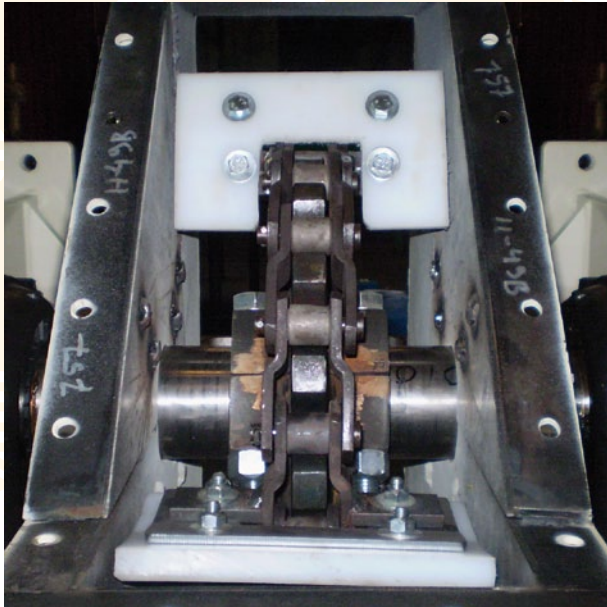

Offset Sidebar Heavy Duty Bush Chains

This series has developed in the US grain industry as an alternative to Welded steel chain in high capacity grain handling equipment. The chain construction is as KING JKB style with a pressed bush and pin. The link plates maintain the crank link form. There are five main standards within the series which loosely follow the Welded steel range. Other varieties can be offered (request details of John King works standard MX series chains). The flight formats will be as welded steel chain (P.13) with polyethylene flights in various forms bolted to steel backing plates which in turn are welded to the chain.

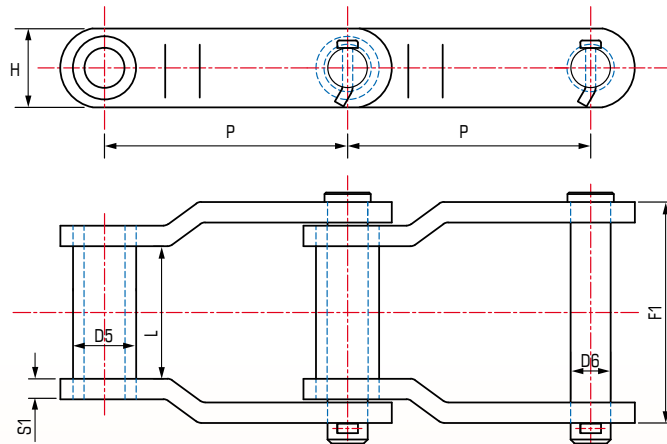

Offset Sidebar Heavy Duty Bush Chains

Chain Number	P	Breaking Load	Average Weight	Rollers	Bushings Outside Diameter	Between Sidesbars	Sidesbars		Pins	Overall Width
							Thickness	Height	Diameter	
							S1	H	D6	
inches										
JKB82H/C	3.00	41,000	6.20	-	1.125	1.19	0.313	1.50	0.56	2.94
JKB124H/C	4.00	60,000	9.50	-	1.125	1.94	0.38	2.00	0.63	4.00
JKB106H/C	6.00	60,000	9.50	-	1.125	1.94	0.38	2.00	0.63	4.00
JKB132H/C	6.00	105,000	13.80	-	1.50	2.125	0.50	2.50	0.875	4.80
JKC155H/C	6.00	148,000	20.00	-	1.75	2.50	0.56	3.00	1.13	5.56

Note: Specifications based on standard material and heat treatment. Options of austenitic stainless steel plates and hardening stainless materials for pin and bushes available on request.



Certificate of Registration

QUALITY MANAGEMENT SYSTEM - ISO 9001:2008

This is to certify that:

John King Chains Ltd
New Climax Works
Lancaster Way
Sherburn in Elmet
Leeds
LS25 6NS
United Kingdom

Holds Certificate No: **FM 77342**
and operates a Quality Management System which complies with the requirements of ISO 9001:2008 for the following scope:

The manufacture, procurement and supply of conveying chains, sprockets and ancillary components including engineered steel, cast link, forged link and Acetal chains including related processes of machining, laser profiling, forming and general fabrication

For and on behalf of BSI:

Gary Fenton, Global Assurance Director

Originally registered: 15/11/2003

Latest Issue: 25/05/2012

Expiry Date: 24/07/2015



Page: 1 of 1

This certificate was issued electronically and remains the property of BSI and is bound by the conditions of contract.
An electronic certificate can be authenticated at www.bsigroup.com/ClientsDirectory



Information and Contact: BSI, Kilnmarket Court, Davy Avenue, Knowlhill, Milton Keynes MK9 8PP. Tel: +44 (0)1509 600000
BSI Assurance UK Limited, registered in England under number 7805321 at 389 Chiswick High Road, London W6 4AL, UK.
A Member of the BSI Group of Companies.



Change of use for redundant silos in Rosario, Argentina. The grain processing capital of the world.



JOHN KING



John King Chains Limited

New Climax Works,
Lancaster Business Park,
Sherburn-in-Elmet LS25 6NS UK
Tel: (44) 1977 681 910
Fax: (44) 1977 681 899
Email: general@johnkingchains.co.uk

John King USA Inc.

200 Catherine Street, Unit 7, Box 8,
East Peoria, USA IL 61611
Tel: (1) 309 698 9250
Fax: (1) 309 698 9259
Email: sales@johnkingchains.com

John King Chains (SA) (PTY) Ltd.

No. 17 N12 Airport Industrial Park,
Dr. Vosloo Road, Barletts, Boksburg,
Johannesburg
Tel: (27) 11 894 3570
Fax: (27) 11 894 3501
Email: sales@jkc.co.za

Cadenas John King Ltda.

Panamericana 5 Sur Km. 34
Parcela 13 – Lote C
Buin – Santiago, Chile
Fonos: (56) 2517 7313
Email: manuel@johnkingchains.com

John King Chains (Central Europe)

ul. Grunwaldzka 182
85-401 Bydgoszcz, Poland
Tel/Fax: (48) 52 349 08 97
Mobile: (48) 600 871 077
Email: aw@johnkingchains.com



REG NO: FM77342

www.johnkingchains.com