



TIMBER PROCESSING CHAINS



CLIMA+
Linking you to EXCELLENCE since 1926

JOHN KING



JOHN KING & COMPANY

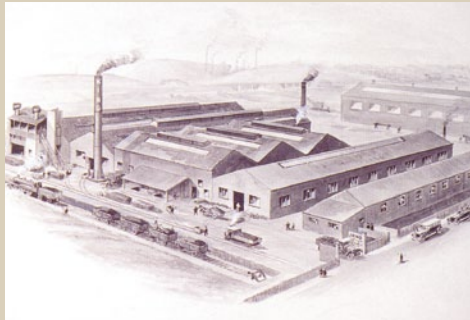

Climax Works 1930's



Chain Assembly 1960's



New Climax Works 2000's

Company History and Qualifications

The John King Company was established in Leeds, England in 1926. Early success was achieved in the manufacture of mechanical handling equipment for the rapid mechanisation of the coal industry. In these early days conveyor chain was generally of cast link construction. The Company therefore has unrivalled experience in the production of highest quality cast link chains in ductile irons and steel under the "Climax Quality Brand". JOHN KING are undoubtedly the world leaders in this range of conveying chains.

Although cast link chains remain an important part of the JOHN KING programme, the company has progressively expanded the product range to encompass chains of other constructions and manufacturing techniques including Welded steel chains, engineered steel chains, forged fork link chains and Engineering plastic chains. Today JOHN KING offer the widest range of conveyor chains of any manufacturer which makes them unique in being able to offer an infinite number of chain types in a variety of materials and constructions for a multiplicity of industry mechanical handling applications.

In recent years it has been JOHN KING's strategy to develop the Company into a global business. This has seen the establishment, in addition to the United Kingdom, of a chain production plant in the US. John King USA Inc from their plant in East Peoria (IL) are well equipped with the manufacturing equipment for component production and assembly processes for high quality chain production serving North America. To provide best service in export markets the companies has warehousing and distribution worldwide and maintain ambition plans to expand the network further in the future.

All products are manufactured within the dictates of the Company's quality management according to ISO 9000 establishing consistent and high quality products and ensuring performance reliability and extended service life.

CONTENTS

Offset Sidebar Welded Steel Chains **03** | King M Series Equivalent Welded Steel Chains **03** | Offset Sidebar Welded Steel Chains for High Duty Timber Applications **04** | Welded Steel Drag Chains **05** | M Series Chains **06** | M112A100/F2 **07** | M112A100/L2 **07** | M112A100/T2 **07** | M160A160/L2 **07** | FV Series Chains **08** | FV140A125/F2 **09** | FV140A125/L4 **09** | FV90A100/RT **09** | FV180A100/W370 **09** | FV250A160/W370 **10** | FV250A125/W420 **10** | FV250A250/W440/SP **10** | FV180/160/R70/L4/SP **11** | FV250/160/R70/L4/SP **11** | Chip Press Chains **12** | Climax Case Chains **12** | 81X Chains **13** | 81X RT Chains **13** | Forged Link Standard Series **14** | Forged Link Double Series **15** | Typical Flight Arrangements **15** | Metric Welded Bush Chains **16** | British Standard Sharp Top Chains **18** | American Standard Sharp Top Chains **19**

Offset Sidebar Welded Steel Chains

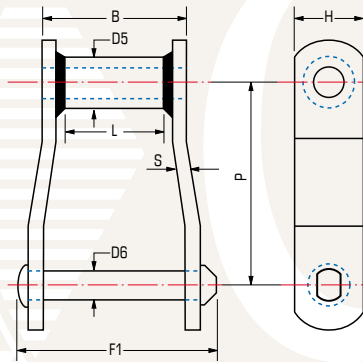

Offset Sidebar Welded Steel Chains

Chain Number	P	Breaking Load	Average Weight	Over-All Pin & Cotter	Between Sidebars	Sidebars		Rivets	Bushings	Length of Bearing
						Thickness	Height	Diameter	Outside Diameter	
						F1	L	S	H	
inches										
WH78/R	2.609	33,000	4.30	3.00	1.00	0.25	1.25	0.50	0.84	2.00
WH82/R	3.075	36,000	4.70	3.38	1.13	0.25	1.25	0.56	1.00	2.25
WH124/R	4.000	57,000	7.80	4.25	1.50	0.38	1.50	0.75	1.25	2.75
WH111/R	4.760	60,000	8.60	4.81	1.75	0.38	1.75	0.75	1.25	3.38
WH110/R	6.000	50,500	7.00	4.00	1.88	0.38	1.50	0.75	1.25	3.00
WH106/R	6.000	60,000	6.20	4.25	1.50	0.38	1.50	0.75	1.25	2.75
WH132/R	6.050	122,000	14.10	6.38	2.75	0.50	2.00	1.00	1.75	4.41
WH150/R	6.050	122,000	16.30	6.50	2.75	0.50	2.50	1.00	1.75	4.41
WH155/R	6.050	175,000	19.00	6.41	2.75	0.56	2.50	1.13	1.75	4.44
WH157/R	6.050	175,000	20.00	6.75	2.75	0.63	2.50	1.13	1.75	4.63
WH159/R	6.125	210,000	26.00	6.75	2.75	0.63	3.00	1.25	2.00	4.63
WH200/R	6.125	190,000	22.10	6.75	2.75	0.63	2.50	1.25	2.00	4.63

Add IBR for fully heat treated parts plus induction hardened barrels and rivets.
Suffix R denotes riveted pin style normal in timber application.

King M Series Equivalent Welded Steel Chains

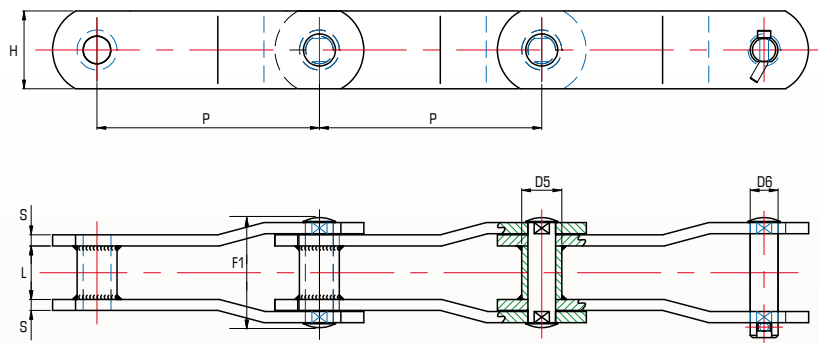

King M Series Equivalent Welded Steel Chains

Chain Number	Pitch	F1	L	S	H	D6	D5	Breaking Load	Weight
	P								
	mm								
WHM224/160/IBR*	160	93	42	8	60	21	42	224	22.87
WHM224/200/IBR*	200	93	42	8	60	21	42	224	19.84
WHM315/200/IBR*	200	99	48	10	70	25	48	315	31.00
WHM315/250/IBR*	250	99	48	10	70	25	48	315	27.00
WHM450/250/IBR*	250	107	56	12	80	30	56	450	41.05
WHM450/315/IBR*	315	107	56	12	80	30	56	450	35.67

* IBR represents uprated timber specification with fully heat treated components together with induction hardened barrel (bush) and pin.

Timber Processing Chains



Offset Sidebar Welded Steel Chains for Heavy Duty Timber Applications

John King offer a series of welded steel chains specifically designed for high impact and abrading resistance as encountered in timber decks and high duty timber applications. The chain includes fully heat treated chain parts with the addition of induction hardened barrels and rivets. Chains are primarily riveted construction with extra large formed rivet head to ensure maximum integrity.

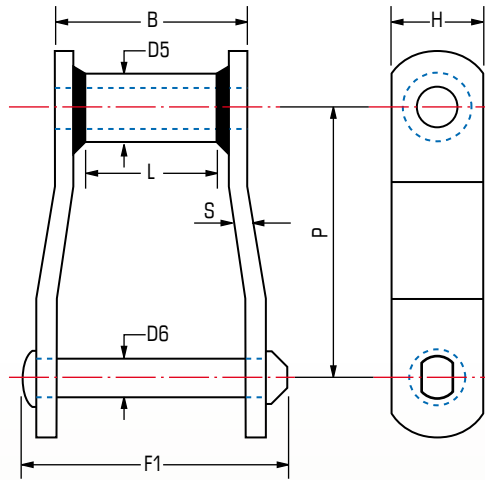

Extra Heavy-Duty Welded Steel Chains

Chain Number	P	Breaking Load	Average Weight	Over-All Pin & Cotter	Between Sidebars	Sidebars		Rivets	Bushings	Length of Bearing
						Thickness	Height	Diameter	Outside Diameter	
						F1	L	S	H	
inches										
WH78XHD	2.636	36,000	6.30	3.38	1.00	0.38	1.25	0.56	1.00	2.00
WH82XHD	3.075	57,000	8.50	3.75	1.13	0.38	1.50	0.75	1.25	2.38
WH124XHD	4.063	122,000	14.60	4.88	1.50	0.50	2.00	1.00	1.63	3.00
WH106XHD	6.050	122,000	11.80	4.88	1.50	0.50	2.00	1.00	1.75	3.00
WH132XHD	6.050	122,000	15.30	6.75	2.75	0.63	2.00	1.00	1.75	4.66

Add IBR or fully heat treated parts plus induction hardened barrels and rivets.



Welded Steel Drag Chains

JOHN KING wide series WDH chains are intended to be used in applications where joint and barrel diameter wear are an issue.

Features include original formed barrel design for complete bearing pin to barrel contact. As with narrow series, many material and heat treatment configurations are available. Special attention is paid to pitch control to ensure that, in multiple strand applications, such as chipper infeeds or live bottom bins there is accurate matching between the strands.

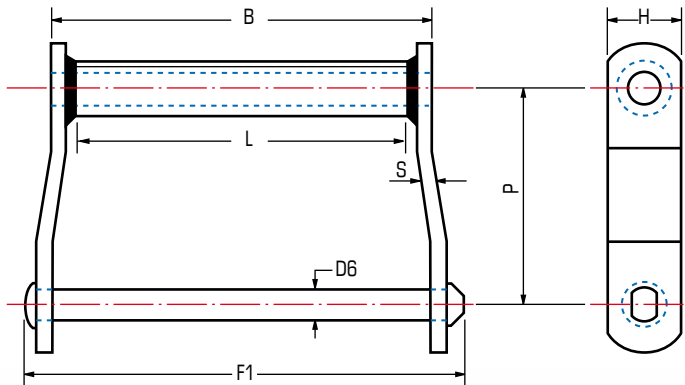

JK Welded Steel Drag Chains

Chain Number	P	Breaking Load	Average Weight	Over-All Width	Between Sidebars	Sidebars		Rivet Diameter	Length Of Bearing
						Thickness	Height		
	inches	lbs	lbs/ft	F1	L	S	H	D6	B
WDH102	5.00	55,000	11.80	9.25	6.38	0.38	1.50	0.75	7.75
WDH104	6.00	55,000	8.50	6.75	4.13	0.38	1.50	0.75	5.38
WDH110	6.00	55,000	12.00	11.75	9.00	0.38	1.50	0.75	10.25
WDH112	8.00	55,000	10.00	11.75	9.00	0.38	1.50	0.75	10.25
WDH116	8.00	59,000	18.50	15.50	13.00	0.38	1.75	0.75	14.13
WDH118	8.00	79,000	21.00	16.63	13.25	0.50	2.00	0.88	14.88
WDH120	6.00	79,000	20.00	12.00	8.75	0.50	2.00	0.88	10.25
WDH480	8.00	79,000	18.00	14.50	11.20	0.50	2.00	0.88	12.75
WDH580	8.00	108,000	19.40	14.63	11.20	0.50	2.00	1.00	12.10
WDH680	8.00	108,000	21.00	15.33	11.20	0.63	2.00	1.00	13.00

Timber Processing Chains

M Series Chains

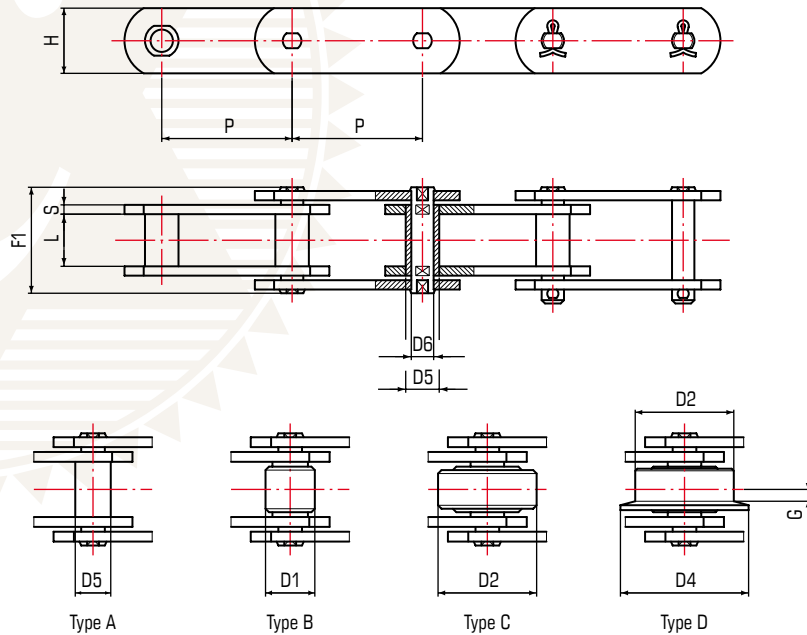

Metric Conveyor Chains ISO 1977 (M Series) DIN 8167

Chain Number	P	Working Load		Average Weight	Rollers				Pins	Over All Pin & Cotter	Bushings	Between Sidebars	Sidebars	
					Style			Flange thickness					Diameter	Diameter
					Bush Type	D1	D2	D4	G	D6	F1	D5		
mm														
M80	80	80	125	4.51	25	50	60	7	12	54.5	18	28	5	35
M80	100	80	125	4.13	25	50	60	7	12	54.5	18	28	5	35
M80	125	80	125	3.83	25	50	60	7	12	54.5	18	28	5	35
M80	160	80	125	3.57	25	50	60	7	12	54.5	18	28	5	35
M80	200	80	125	3.38	25	50	60	7	12	54.5	18	28	5	35
M112	80	112	175	6.30	30	60	75	7.5	15	63	21	32	6	40
M112	100	112	175	5.60	30	60	75	7.5	15	63	21	32	6	40
M112	125	112	175	5.80	30	60	75	7.5	15	63	21	32	6	40
M112	160	112	175	5.37	30	60	75	7.5	15	63	21	32	6	40
M112	200	112	175	4.63	30	60	75	7.5	15	63	21	32	6	40
M160	100	160	260	9.80	36	70	90	8.5	18	72	25	37	7	50
M160	125	160	260	8.50	36	70	90	8.5	18	72	25	37	7	50
M160	160	160	260	7.80	36	70	90	8.5	18	72	25	37	7	50
M160	200	160	260	7.30	36	70	90	8.5	18	72	25	37	7	50
M160	250	160	260	6.90	36	70	90	8.5	18	72	25	37	7	50
M224	125	224	340	12.30	42	85	105	10	21	84	30	43	8	60
M224	160	224	340	11.10	42	85	105	10	21	84	30	43	8	60
M224	200	224	340	10.20	42	85	105	10	21	84	30	43	8	60
M224	250	224	340	6.90	42	85	105	10	21	84	30	43	8	60
M224	315	224	340	8.98	42	85	105	10	21	84	30	43	8	60
M315	160	315	520	19.20	50	100	124	10.5	25	97	36	48	10	70
M315	200	315	520	16.70	50	100	124	10.5	25	97	36	48	10	70
M135	250	315	520	15.60	50	100	124	10.5	25	97	36	48	10	70
M315	315	315	520	14.70	50	100	124	10.5	25	97	36	48	10	70
M315	400	315	520	13.80	50	100	124	10.5	25	97	36	48	10	70
M450	200	45	70	23.90	60	120	149	11.5	30	114	42	56	12	80
M450	250	45	70	22.12	60	120	149	11.5	30	114	42	56	12	80
M450	315	45	70	20.65	60	120	149	11.5	30	114	42	56	12	80
M450	400	45	70	19.45	60	120	149	11.5	30	114	42	56	12	80

* Breaking Load With heat treated Plates

M112A100/F2

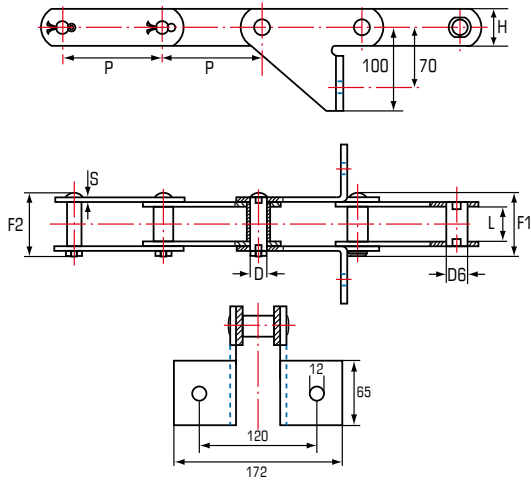

M112A100/L2

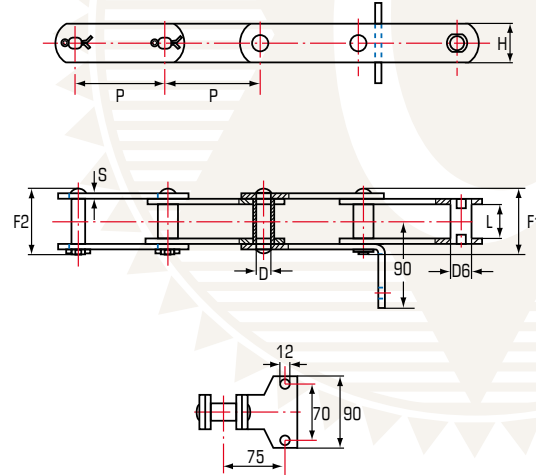

M112A100/T2

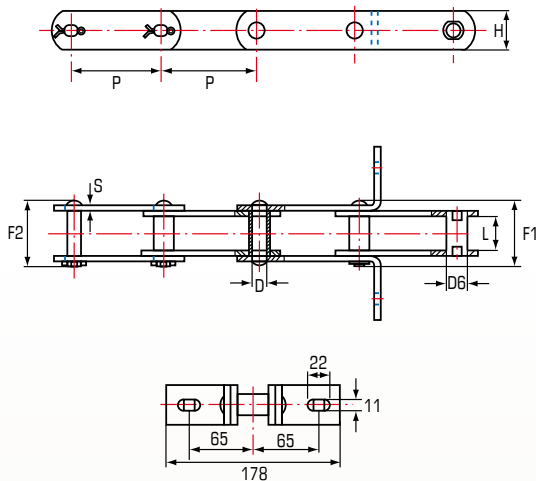

M160A160/L2

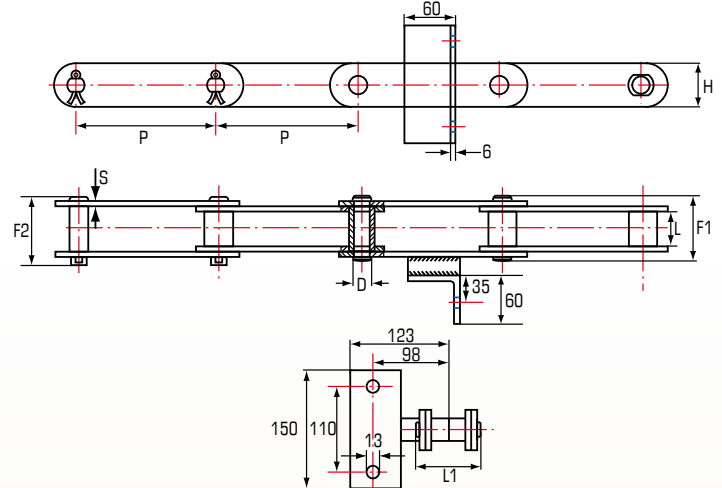

Chains for the Wood Industry

Chain Number	Pitch	Bush/Roller		Pin		Plate		Tensile Strength	
		Width	Diameter	Diameter	Length	Thickness	Height		
	P	L	D6	D	F1	F2	S		H
M112A100/F2	100	32	21	15	65	73	6/6	40	112
M112A100/L2	100	32	21	15	65	73	6/6	40	112
M112A100/T2	100	32	21	15	65	73	6/6	40	112
M160A160/L2	160	37	25	18	74.5	79.5	7	50	160

Timber Processing Chains

FV Series Chains

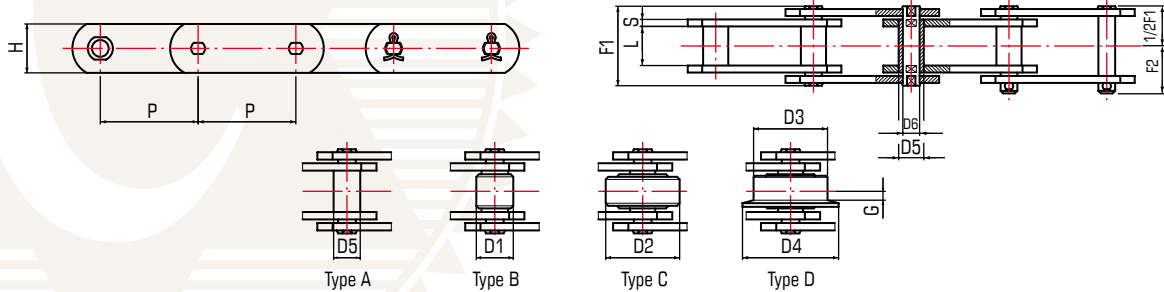

Metric Chains (FV Series) DIN 8165

Chain Number	P	Working Load		Average Weight	Over-All Pin & Cotter		Rollers					Bushings	Between Sidebars	Sidebars		Pins
							Style				Flange thickness	Diameter		Thickness	Height	Diameter
							D1	D2	D3	D4						
mm	kN	kN*	kg/m	F1	F2	mm										
FV63	63	64	75	3.46	45	26	26	40	50	63	5	18	22	4	30	12
FV63	80	64	75	3.73	45	26	26	40	50	63	5	18	22	4	30	12
FV63	100	64	75	2.92	45	26	26	40	50	63	5	18	22	4	30	12
FV63	125	64	75	2.67	45	26	26	40	50	63	5	18	22	4	30	12
FV63	260	64	75	2.45	45	26	26	40	50	63	5	18	22	4	30	12
FV90	63	100	115	5.72	53	30	30	48	63	78	6.5	20	25	5	35	14
FV90	80	100	115	5.20	53	30	30	48	63	78	6.5	20	25	5	35	14
FV90	100	100	115	4.67	53	30	30	48	63	78	6.5	20	25	5	35	14
FV90	125	100	115	4.35	53	30	30	48	63	78	6.5	20	25	5	35	14
FV90	160	100	115	3.87	53	30	30	48	63	78	6.5	20	25	5	35	14
FV90	200	100	115	3.50	53	30	30	48	63	78	6.5	20	25	5	35	14
FV90	250	100	115	3.41	53	30	30	48	63	78	6.5	20	25	5	35	14
FV112	100	120	170	6.11	62	35	32	55	72	90	7.5	22	30	6	40	16
FV112	125	120	170	5.85	62	35	32	55	72	90	7.5	22	30	6	40	16
FV112	160	120	170	5.26	62	35	32	55	72	90	7.5	22	30	6	40	16
FV112	200	120	170	5.00	62	35	32	55	72	90	7.5	22	30	6	40	16
FV112	250	120	170	4.72	62	35	32	55	72	90	7.5	22	30	6	40	16
FV140	100	145	180	7.38	67	38	36	60	80	100	9.5	26	35	6	45	18
FV140	125	145	180	6.78	67	38	36	60	80	100	9.5	26	35	6	45	18
FV140	160	145	180	6.56	67	38	36	60	80	100	9.5	26	35	6	45	18
FV140	200	145	180	5.82	67	38	36	60	80	100	9.5	26	35	6	45	18
FV140	250	145	180	5.48	67	38	36	60	80	100	9.5	26	35	6	45	18
FV180	125	190	250	10.70	86	49	42	70	100	125	13	30	45	8	50	20
FV180	160	190	250	9.72	86	49	42	70	100	125	13	30	45	8	50	20
FV180	200	190	250	9.12	86	49	42	70	100	125	13	30	45	8	50	20
FV180	250	190	250	8.51	86	49	42	70	100	125	13	30	45	8	50	20
FV180	315	190	250	8.20	86	49	42	70	100	125	13	30	45	8	50	20
FV250	160	275	300	13.00	97	55	50	80	125	155	15	36	55	8	60	26
FV250	200	275	300	11.80	97	55	50	80	125	155	15	36	55	8	60	26
FV250	250	275	300	10.80	97	55	50	80	125	155	15	36	55	8	60	26
FV250	315	275	300	10.00	97	55	50	80	125	155	15	36	55	8	60	26
FV315	160	370	480	20.04	113	70	60	90	140	175	18	42	65	10	70	30
FV315	200	370	480	18.24	113	70	60	90	140	175	18	42	65	10	70	30
FV315	250	370	480	16.79	113	70	60	90	140	175	18	42	65	10	70	30
FV315	315	370	480	15.53	113	70	60	90	140	175	18	42	65	10	70	30
FV315	400	370	480	14.56	113	70	60	90	140	175	18	42	65	10	70	30

* Breaking Load With heat treated Plates

FV140A125/F2

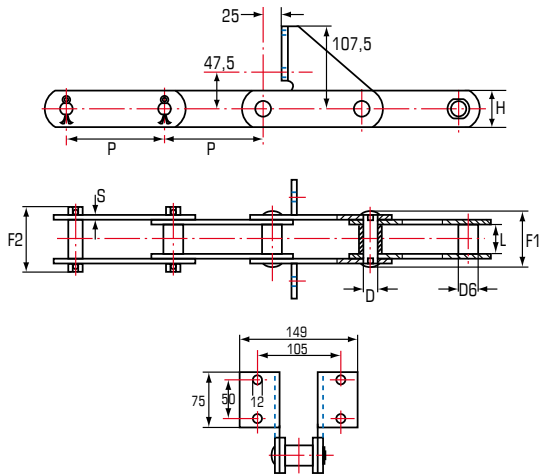

FV140A125/L4

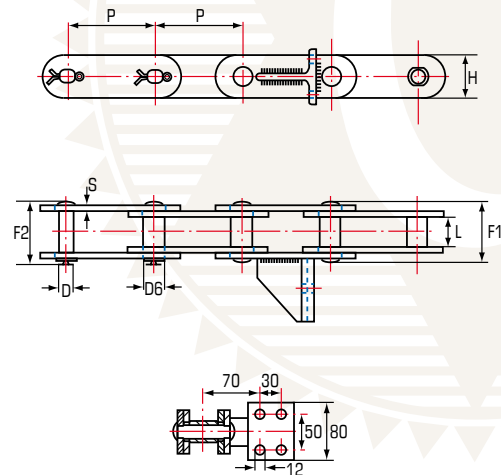

FV90A100/RT

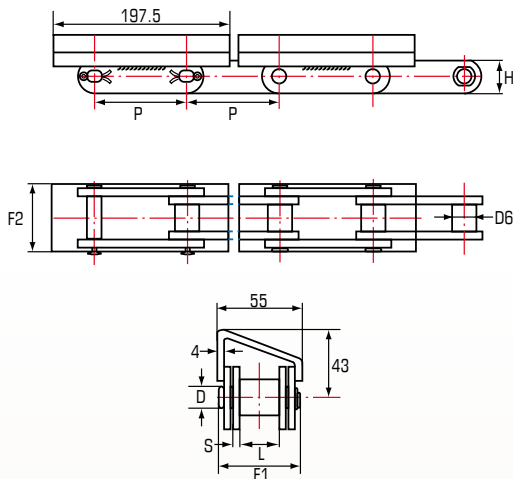

FV180A100/W370

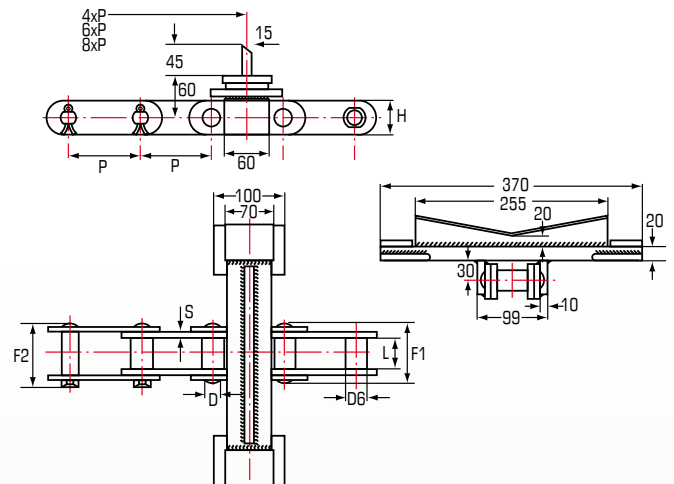

Chains for the Wood Industry

Chain Number	Pitch	Bush/Roller		Pin		Plate		Tensile Strength	
		Width	Diameter	Diameter	Length	Thickness	Height		
	P	L	D6	D	F1	F2	S	H	kN
FV140A125/F2	125	35	26	18	72	77	6/6	45	180
FV140A125/L4	125	35	26	18	72	77	6/6	45	180
FV90A100/RT	100	25	2	14	53	58	5	35	115
FV180A100/W370	100	45	30	20	87	92	8	50	250

Timber Processing Chains

FV250A160/W370

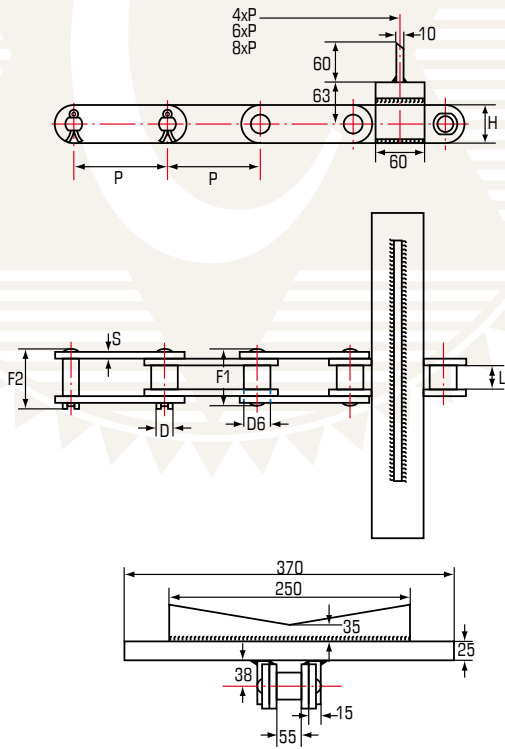

FV250A125/W420

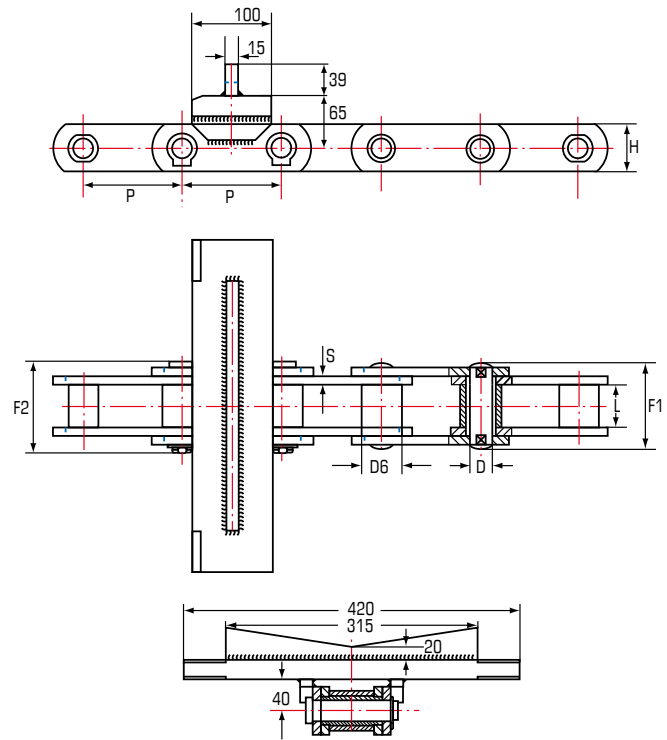

FV250A250/W440/SP

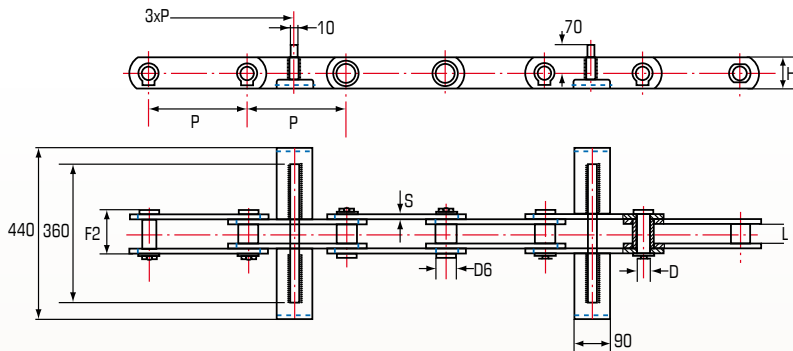

Chains for the Wood Industry

Chain Number	Pitch	Bush/Roller		Pin		Plate		Tensile Strength	
		Width	Diameter	Diameter	Length	Thickness	Height		
	P	L	D6	D	F1	F2	S	H	kN
FV250A160/W370	160	55	36	26	107	115	10	60	250
FV250A125/W420	125	55	50	26	107	115	10	60	250
FV250A250/W440/SP	250	50	50	36	-	123	12	80	250

Special attachments available on application.

FV180/160/R70/L4/SP

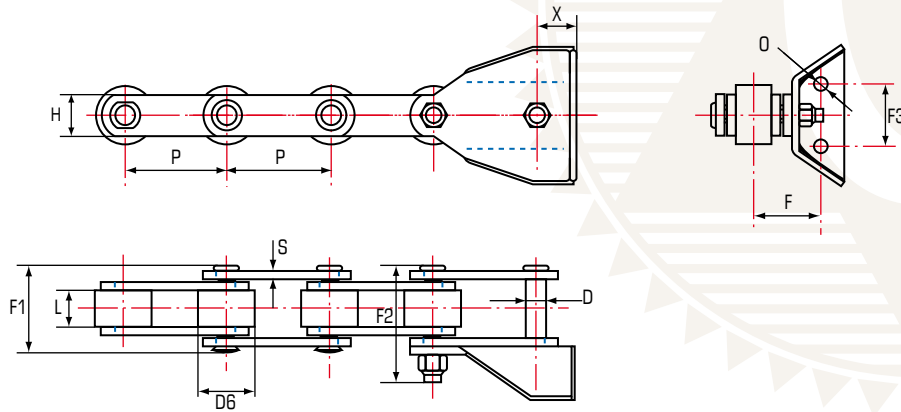

FV250/160/R70/L4/SP

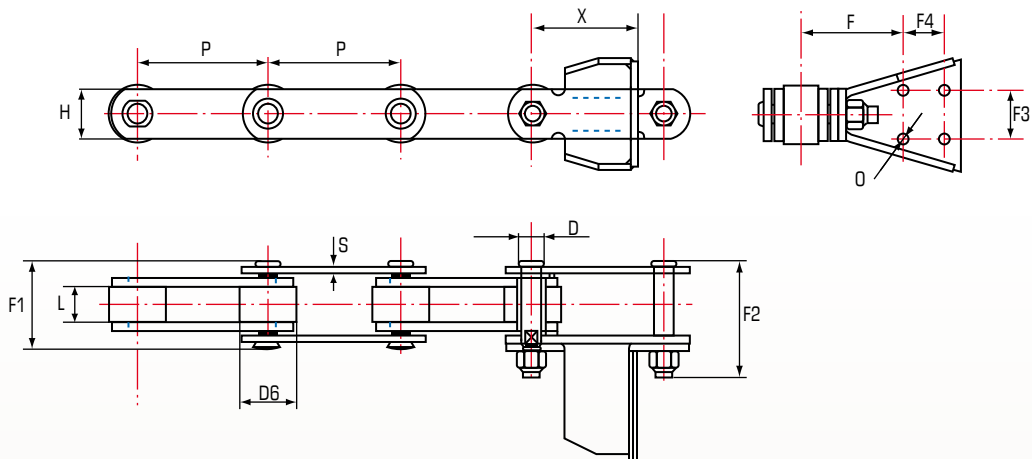

Chains for the Wood Industry

Chain Number	Pitch	Roller		Pin			Plate		F3	F	O	X	F4	Tensile Strength
		Width	Diameter	Diameter	Length		Thickness	Height						
	P	L	D6	D	F1	F2	S	H	mm					kN
FV180/160/R70/L4/SP	125	45	70	20	90	122	8	50	75	77.5	16.5	44	-	250
FV250/160/R70/L4/SP	160	45	70	25	99	136	10	60	60	119.5	13	130	50	400

Special attachments available on application.

Timber Processing Chains

Chip Press Chains

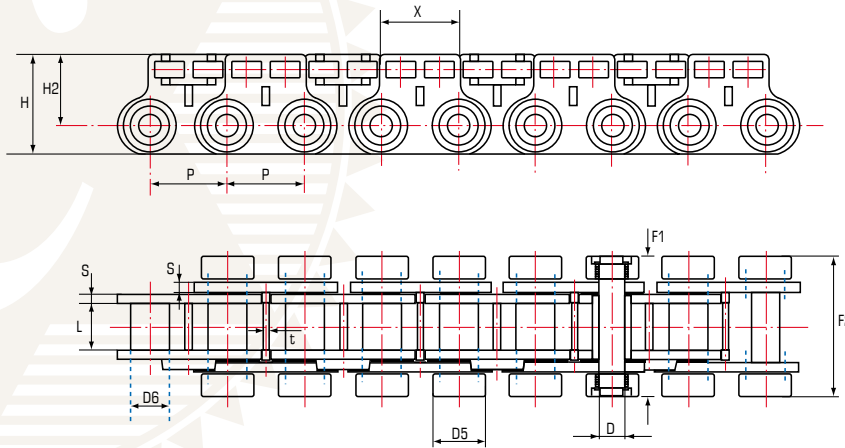

Chip Press Chains

Chain Number	Pitch P	Bush		Pin		Plate		X	F2	H2	D5	t	Tensile Strength kN
		Width L	Diameter D6	Diameter D	Length F1	Thickness S	Height H						
mm													
D5460	40	20	25	14	73	5	53	42	75	38	28	4	90



Climax Case Chains

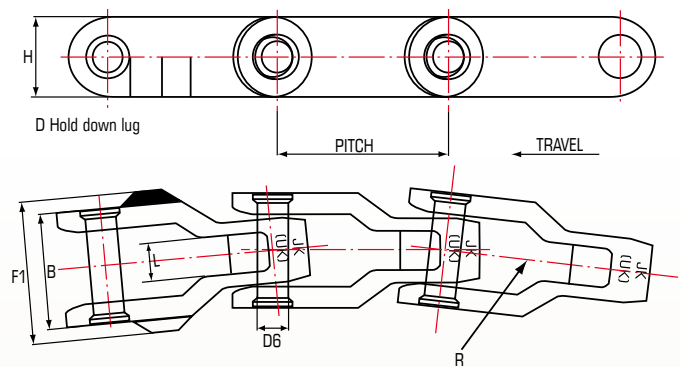

Climax Case Chains

Chain Number	Average Pitch	Length of Bearing	Pin Diameter	Sprocket Face	Sidebars Height	Over-All	Number of Links in 10 Ft	Average Weight	Minimum Turning Radius
	P	B	D6	L	H	F1		lbs/ft	inches
inches									
CC600	2.52	1.69	0.44	0.50	1.13	1.69	48	11.40	19
CC600D	2.52	1.69	0.44	0.50	1.13	2.13	48	12.20	19
CC1300	3.25	2.06	0.56	0.38	1.50	2.06	37	11.30	40
CC1300D	3.25	2.06	0.56	0.38	1.50	2.69	37	13.00	40

81X Chains

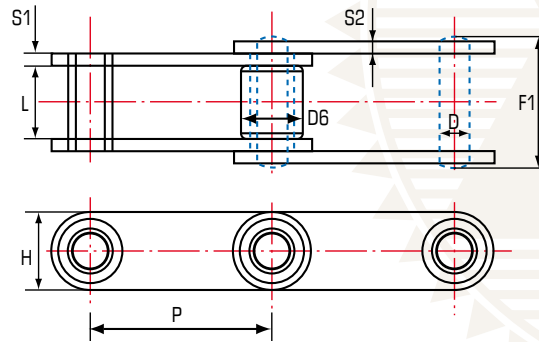

Chains for the Wood Industry

Chain Number	Pitch	Roller		Pin		Plate		Height	Tensile Strength
		Width	Diameter	Diameter	Length	Thickness			
	P	L	D6	D	F1	S1	S2	H	kN
JK81X	66.27	27	23	11.11	47.2	4	4	28.58	111
JK81XH	66.27	27	23	11.11	58.2	7.94	5.56	31.75	176
JK81XHH	66.27	27	23	11.11	63.5	7.94	7.94	31.75	186

81X RT Chains

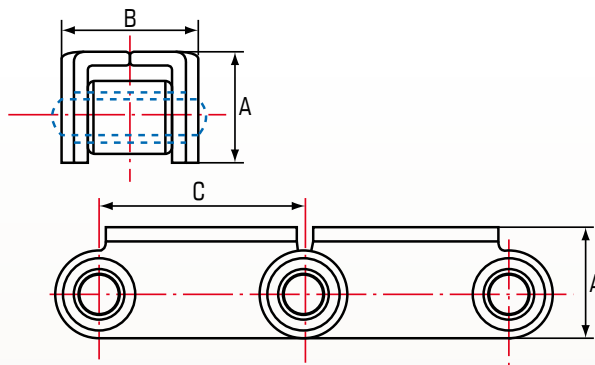

Chains for the Wood Industry

Chain Number	C	B	A
JK81X RT	66.27	38.1	46.04

Available in XH and XHH version with UHMWP or Steel Caps



Forged Link Standard Series

This series represents the leading product within the John King programme. Forged fork link chain has proven to be one of the most reliable conveying mediums offering a combination of versatility, strength and abrasion resistance. These chains, originally of European origin, are now established worldwide. With a wide variety of materials, heat treatments and flight formats the chain is proven in both drag and enmasse handling.

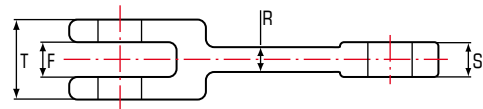
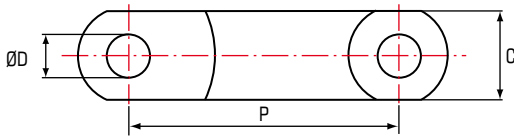

Forged Link Standard Series

Chain Number	P	T	C	S	F	R	Bolt Hole Diameter D	Breaking Loads			Weight kg/m
								TN	CN	CD	
JKF 10160	101.6	24	36	8	10	6	14	110	120	210	3.50
JKF 10160R	101.6	30	36	13	14	9	14	180	195	330	4.80
JKF 12514	125	30	36	13	14	10	16	163	175	290	4.40
JKF 14214	142	30	40	13	14	9	18	180	195	330	4.90
JKF 14218	142	42	50	19	20	11	25	290	320	550	9.40
JKF 14222	142	54	50	25	27	16	25	370	400	655	12.20
JKF 14226	142	62	50	28	30	15	25	440	470	790	13.60
JKF 16018	160	46	46	22	24	15	22	320	342	560	9.30
JKF 16025	160	50	53	23	25	13	25	370	400	655	10.80
JKF 20025	200	60	50	25	27	18	25	380	410	670	11.30
JKF 20028	200	66	60	30	32	20	30	500	540	900	16.70
JKF 21640	216	64	72	26	28	20	35	585	630	1035	20.10
JKF 22040	220	64	72	26	28	20	35	585	630	1035	20.30
JKF 22050	220	58	75	28	30	25	32	710	760	1260	19.10
JKF 22060	220	71	75	31	33	21	35	735	790	1300	22.90
JKF 25040	250	70	75	32	34	18	32	735	860	1430	18.80
JKF 26035	260	65	75	31	33	20	32	840	900	1480	19.80
JKF 26040	260	70	75	31	33	20	32	840	900	1480	21.00
JKF 26045	260	78	75	35	37	20	32	930	1000	1650	21.80

* Attachment hole positions and sizes can be varied to meet customer requirements. Dimensions in metric measure.



Forged Link Double Series

For double strand assemblies John King have a range of links following the standard format but with a forged "double clevis" into which a scraper can be mounted. The flight blade can be retained by either a U bolt or standard fasteners. The chain allows for some built in clearance between strands which obviates any potential problems that may be associated with mismatch. Double strands allows for improved discharge particularly relevant in conveying sticky materials.

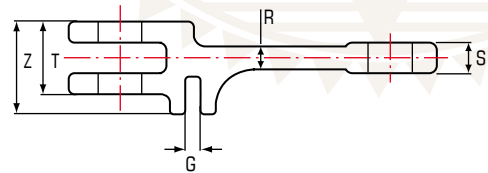
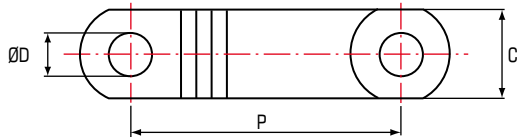

Forged Link Double Series

Chain Number	P	T	C	S	Z	G	Bolt Hole Diameter D	Breaking Loads			Weight kg/m
								TN	CN	CD	
mm											
JKF 142182	142	42	50	19	70	13	25	290	320	550	11.80
JKF 142262	142	62	50	28	87	13	25	440	470	790	16.70
JKF 160252	160	50	53	23	82	13	25	370	400	655	13.60
JKF 175402	175	72	60	30	95	16	30	540	580	955	20.30
JKF 200252	200	60	50	25	81	12	25	380	410	670	13.00
JKF 200402	200	70	60	30	95	13	30	540	580	955	19.30
JKF 250252	250	60	50	25	81	12	25	380	410	670	12.00
JKF 250402	250	70	60	30	95	13	30	540	580	955	17.70
JKF 250602	250	100	70	45	140	21	35	975	1050	1720	35.20

* Attachment hole positions and sizes can be varied to meet customer requirements. Dimensions in metric measure.

Typical Flight Arrangements

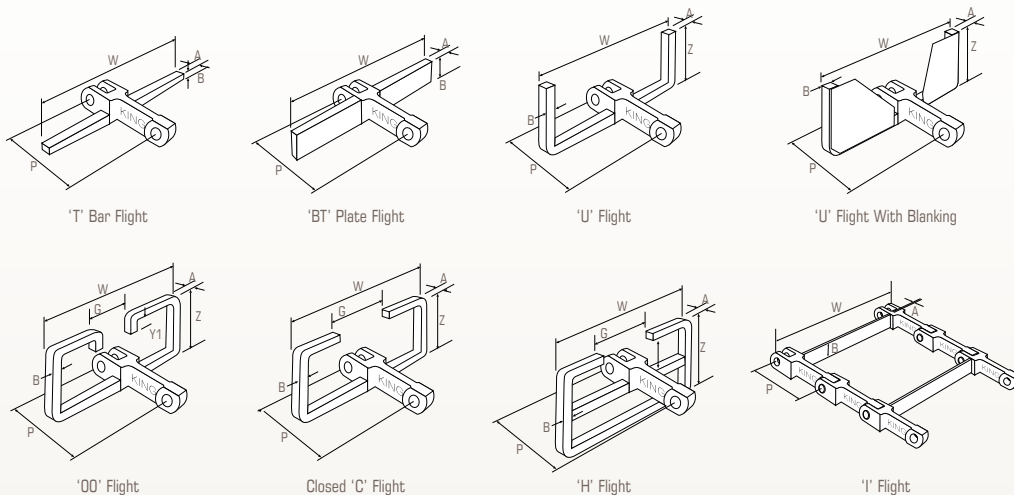

* John King sprockets also available.



Metric Welded Bush Chains

These chains have proven to be the most reliable conveying medium when it comes to the aggressive nature of log yard applications. They are typical where continued impact and abrasion affect the operational life of the chain system employed. These chains include fully heat treated parts, with welded pin and bush to ensure maximum chain life and performance.

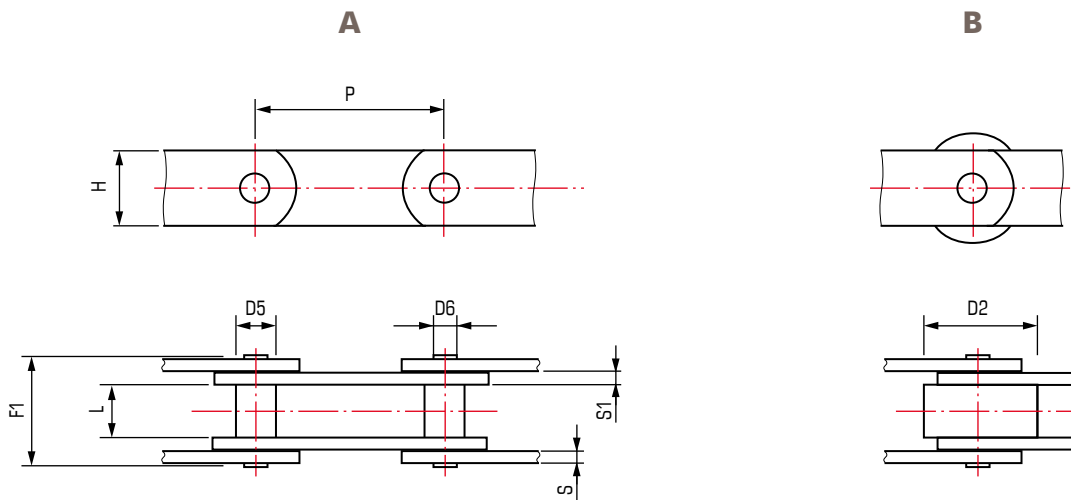

JKB500

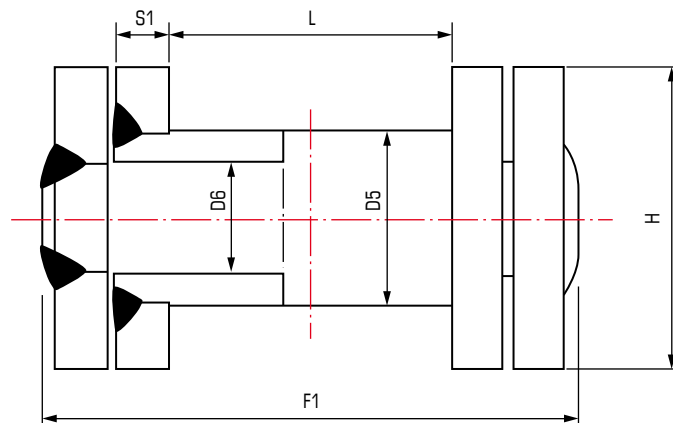

Metric Welded Bush Chains

Chain Number	Breaking Load kN	Pitch P	Inner width L	Pin D6	Bush D5	Side plates				Plain roller D2	Outer width F1	Weight			
						Height H	Thickness		S, Grov			A	A, Grov	B	B, Grov
							S1	S							
JKB5,5	55	63	22	12	18	30	5	4	6	40	50	4.0	4.6		
		80										3.6	4.2		
		100										3.4	4.0	5.0	5.6
JKB8,5	85	80	25	14	20	35	6	5	8	50	59	5.2	6.4		
		100										4.8	5.8	8.0	9.0
		150										4.2	5.2	6.4	7.4
JKB12,5	125	100	35	18	25	40	8	6	8	60	75	7.8	8.6		
		150										6.6	7.4	11.4	12.2
JKB18	240	150	45	20	30	50	8	6	10	70	91	9.2	11.2	16.4	18.4
		200										8.2	10.2	13.8	15.8
JKB24	350	150	55	26	36	60	10	8	12	80	110	14.5	17.0	26.0	28.5
		200										13.5	16.0	22.0	24.5
		250										12.5	14.5	19.5	21.5
JKB30	400	150	65	30	42	70	10	8	12	90	121	19.0	22.5	36.0	39.5
		200										17.0	20.0	29.5	32.5
		250										15.5	18.5	26.0	29.0
JKB40	520	200	80	36	50	80	12	10	12	110	142	26.0	27.5	49.0	50.5
		250										23.5	25.0	41.5	43.0
JKB65	800	200	80	36	50	90	15		15	110	154	34.5	37.5	57.5	60.5
		250						31.5				34.0	50.0	52.5	
JKB500	500	160	65	26	40	70	12			55	124	22.5			
		200						20.8							

Options (*) Specifications (x) = basic	JKB5,5	JKB8,5	JKB12,5	JKB18	JKB24	JKB30	JKB40	JKB65	JKB500
* Side plates with induction hardened wear surfaces				*	*	*	*	*	*
With case hardened bushings	x	x	x	x	x	x	x	x	x
With case hardened pins				x	x	x	x	x	x
With induction hardened pins	x	x	x						
With welded pins	*	*	*/x	x	x	x	x	x	x
With welded bushings				*/x	x	x	x	x	x
With stainless pins + bushings	*	*	*	*	*	*	*	*	*
Side plates with smoothed corners	*	*	*	*	*	*	*	*	*
Lubricated joints	x	x	x	x	x	x	x	x	x

Timber Processing Chains

British Standard Sharp Top Chains

(5 PEP) Series

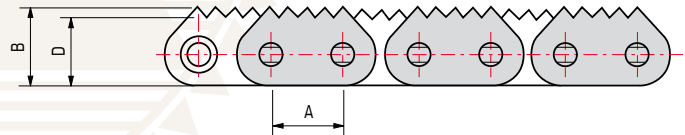

British Standard Sharp Top Chains (5 PEP) Series

Chain Number	A	B	D
	mm		
12B-1	19.05	21.10	12.35
12B-2	19.05	21.10	12.35
16B-1	25.40	26.50	21.10
16B-2	25.40	26.50	21.10
20B-1	31.80	32.80	26.42
20B-2	31.80	32.80	26.42
24B-1	38.10	38.50	33.40
24B-2	38.10	38.50	33.40

32B-1 (2PEP)

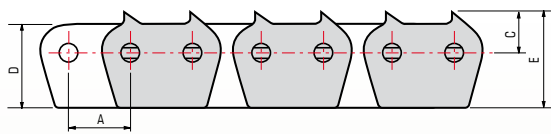

STYLE 1

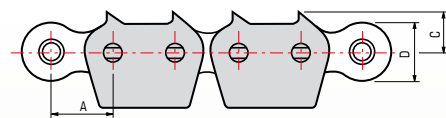

STYLE 2

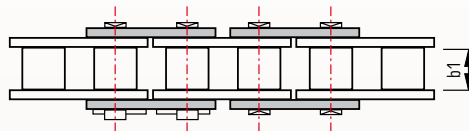

British Standard Sharp Top Chains 32B-1 (2PEP)

Chain Number	b1	A	C	D (STYLE 1)	D (STYLE 2)	E
	mm					
32B-1 Narrow	17.02	50.80	30.00	64.00	41.00	73.00
32B-1 Standard	30.99	50.80	30.00	64.00	41.00	73.00

American Standard Sharp Top Chains

3-Point (ST) Series

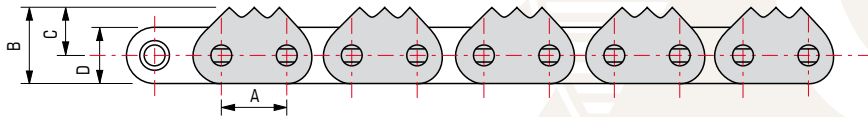

4 PEP – (4 Point Every Pitch)

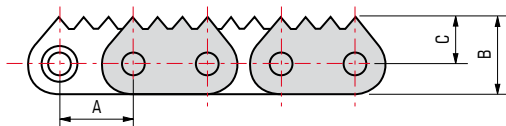

5 PEP Series – (5 Point Every Pitch)

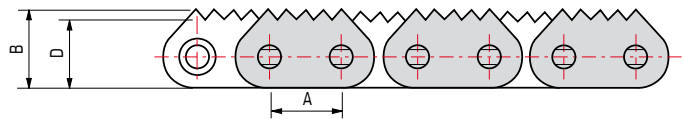

160-1-DP Series

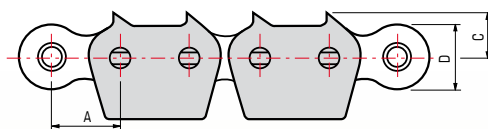

American Standard Sharp Top Chains

Chain Number	A	B	C	D
	inches			
60-1 ST	0.750	0.850	0.512	0.689
60-2 ST	0.750	0.854	0.510	0.685
80-1 ST	1.000	1.140	0.685	0.914
80-2 ST	1.000	1.043	0.630	–
80-3 ST	1.000	1.142	–	1.028
80-4 ST	1.000	1.142	–	1.028
100-1 ST	1.250	1.325	0.750	1.142
100-2 ST	1.250	1.325	0.715	1.147
100-3 ST	1.250	1.325	0.754	1.147
120-1 ST	1.500	1.594	0.909	1.370
120-2 ST	1.500	1.594	0.909	1.370
120-4 ST	1.500	1.594	0.909	1.370
160-1-DP	2.000	–	1.301	1.850



JOHN KING



John King Chains Limited
New Climax Works,
Lancaster Business Park,
Sherburn-in-Elmet LS25 6NS UK
Tel: (44) 1977 681 910
Fax: (44) 1977 681 899
Email: general@johnkingchains.co.uk

John King Chains (SA) (PTY) Ltd.
No. 17 N12 Airport Industrial Park,
Dr. Vosloo Road, Barletts, Boksburg,
Johannesburg
Tel: (27) 11 894 3570
Fax: (27) 11 894 3501
Email: sales@jkc.co.za

**John King Chains
(Central Europe)**
ul. Grunwaldzka 182
85-401 Bydgoszcz, Poland
Tel/Fax: (48) 52 349 08 97
Mobile: (48) 600 871 077
Email: aw@johnkingchains.com

John King USA Inc.
200 Catherine Street, Unit 7, Box 8,
East Peoria, USA IL 61611
Tel: (1) 309 698 9250
Fax: (1) 309 698 9259
Email: sales@johnkingchains.com

Cadenas John King Ltda.
Panamericana 5 Sur Km. 34
Parcela 13 – Lote C
Buin – Santiago, Chile
Fonos: (56) 2517 7313
Email: manuel@johnkingchains.com



REG NO: FM77342

www.johnkingchains.com